



Bringing Ceramic  
Technology to Industry

BORIDE PRODUCTS

# abrasive blast nozzle catalog



## **INTRODUCTION**

Welcome to the Boride Products blast nozzle catalog. Inside you'll find nozzles for just about every abrasive blasting job...and several options in every case. You'll also find tips and guidelines on nozzle selection to help be sure you're able to optimize your investment in our products.

Of course, no catalog can anticipate and answer all your questions. That's why the most important information in this catalog is probably our phone and fax numbers:

**Phone (800) 662-2131 or (231) 946-2100**

**Fax (800) 662-2132 or (231) 946-3025**

Please call or fax us with any questions you have. Our sales people are nozzle and abrasive blasting experts—they have more knowledge and experience than you'll find at most equipment companies. And if you're looking for a Boride dealer nearby, we can help you with that, too.

**Visit our web site at [www.boride.com](http://www.boride.com)**

**Guide to blasting nozzle selection**.....2  
 Air and pressure requirements ..... 3  
 Air and pressure chart ..... 4  
 Bore size and nozzle materials ..... 5  
 Tips on maintenance ..... 6

**Product review**.....7



**Venturi nozzles**  
 Long venturi nozzles  
     Tungsten carbide ..... 8  
     Tungsten carbide wide throat ..... 9  
     Silicon carbide composite ..... 11  
     Boron carbide ..... 12  
 Medium length venturi nozzles and inserts  
     Tungsten carbide ..... 13  
     Boron carbide ..... 13  
 Short length venturi nozzles and inserts  
     Tungsten carbide ..... 15  
     Boron carbide ..... 16



**Special venturi nozzles**  
 Double venturi  
     Tungsten carbide ..... 17  
     Silicon carbide composite ..... 17  
 BAZOOKA® nozzles  
     Tungsten carbide ..... 18  
 Hose insert  
     Tungsten carbide ..... 18



**Straight bore nozzles**  
 Long straight bore  
     Tungsten carbide ..... 19  
     Boron carbide ..... 19  
 Medium length straight bore nozzles and inserts  
     Aluminum oxide (ceramic) ..... 21  
     Tungsten carbide ..... 21  
     Boron carbide ..... 22  
 Short length straight bore nozzles and inserts  
     Aluminum oxide (ceramic) ..... 24  
     Tungsten carbide ..... 25  
     Boron carbide ..... 30



**Angle nozzles**  
     Tungsten carbide ..... 34



**Wet blast nozzles**  
     WIN System (Water Induction Nozzles) ..... 38  
     Siphon blast short ..... 39



**RS-2000 abrasive blasting guns** ..... 40  
     Replacement parts, nozzles, and air jets for RS-2000 blast gun ..... 41  
**Accessories** ..... 42

# A GUIDE TO BLASTING NOZZLE SELECTION

Choosing the right blast nozzle for each application is simply a matter of understanding the variables that affect cleaning performance and job costs. There are four basic questions to answer for optimum cost/performance.

## WHAT BLAST PATTERN DO YOU WANT?

A nozzle's bore shape determines its blast pattern. Nozzles generally have either a straight bore or a restricted, venturi bore. **Straight Bore** nozzles (Figure 1, Number 1) create a tight blast pattern for spot blasting or blast cabinet work. These are best for smaller jobs such as parts cleaning, weld seam shaping, cleaning handrails, steps, grillwork, or carving stone and other materials.

**Venturi bore** nozzles (Figure 1, Numbers 2 and 3) create a wide blast pattern and increase abrasive velocity as much as 100% for a given pressure. Venturi nozzles are the best choice for greater productivity when blasting larger surfaces. Long venturi style nozzles like the BRUISER® blasting nozzles, for example, yield about a 40% increase in productivity compared to straight bore nozzles, while abrasive consumption can be cut approximately 40%.

Double venturi and wide throat nozzles are enhanced versions of the long venturi style nozzle.

The **double venturi** style (Figure 1, Number 4) can be thought of as two nozzles in series with a gap and holes in between to allow the insertion of atmospheric air into the downstream segment of the nozzle. The exit end is also wider than a conventional nozzle. Both modifications are made to increase the size of the blast pattern and minimize the loss of abrasive velocity.

**FIGURE 1. NOZZLE TYPES**

1. Straight bore
2. Conventional design long venturi
3. Laminar flow design long venturi
4. Double venturi
5. High pressure

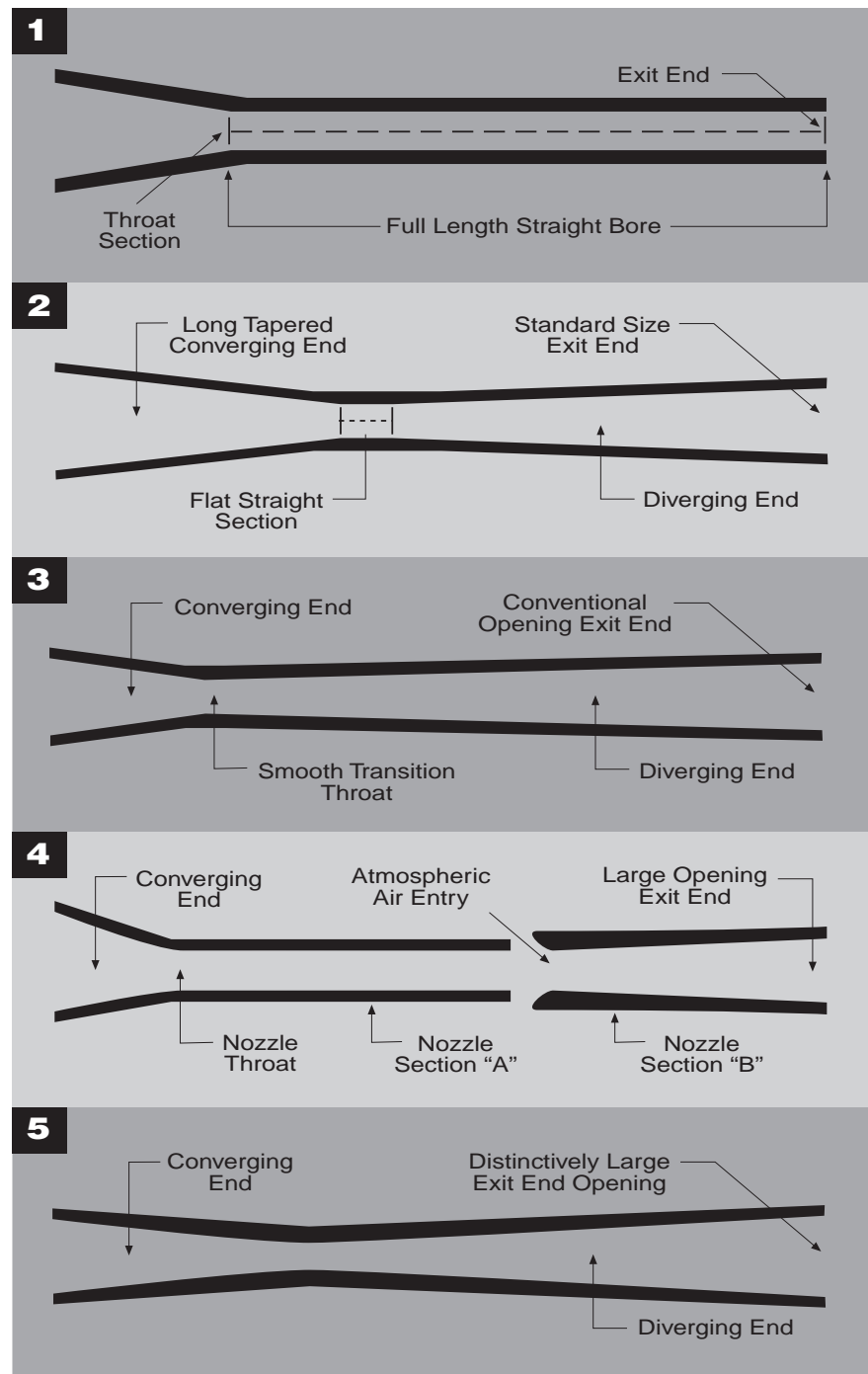

**Wide throat nozzles** (Figure 1, Number 5) feature a large entry throat and a large, diverging exit bore. When matched with the same sized hose they can provide a 15% increase in productivity over nozzles with a smaller throat. When wide throat nozzles also feature a larger diverging exit bore (e.g., BAZOOKA® nozzle), they can be used at higher pressures to yield up to a 60% larger pattern with lower abrasive use.

It's also a good idea to have **angle nozzles** available for tight spots like bridge lattice, behind flanges, or inside pipes. Many operators waste abrasive and time waiting for ricochet to get the job done. The little time it takes to switch to an angle nozzle is always quickly recovered and total time on the job is reduced.

**CAN YOUR COMPRESSED AIR SUPPLY SUPPORT THE NOZZLE?**

As a general rule, the air supply system should be able to provide at least 50% more air volume (cfm) than a new nozzle would need to develop the required working blasting pressure, whether that is 100 psi or 140 psi. This ensures a nozzle can continue to provide good service even after it is slightly worn. Remember, though, excessive wear should not be allowed or productivity decreases dramatically.

Keep in mind, too, the nozzle entry throat must match the inside diameter of your air supply hose. The wrong size combination can lead to wear points, pressure drop, and excessive internal turbulence.

**FIGURE 2. NOZZLE PERFORMANCE COMPARISON**

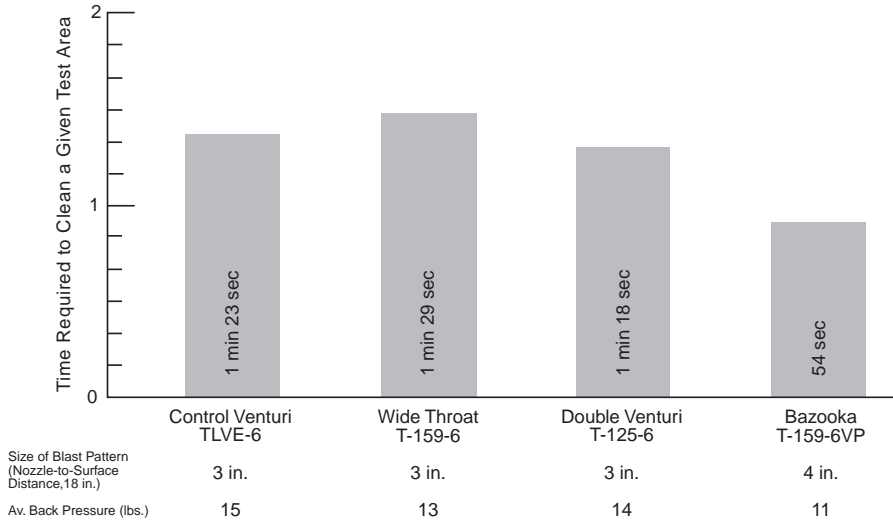

Data compares the time required of different nozzles to clean a given test area based on the nozzle's blast pattern. Also shown is the average back pressure exerted by each nozzle, an indicator of the effect of nozzle selection on operator fatigue.

**MATCHING NOZZLE SIZE AND COMPRESSOR SIZE FOR REQUIRED PRODUCTION RATE**

Production rate required (sq. ft./hr)	Blast nozzle orifice	Production rate at 100 psi nozzle pressure	Production rate at 90 psi nozzle pressure	Production rate at 80 psi nozzle pressure	Compressor size CFM at 100 psi nozzle pressure
Up to 100	1/4"	100	85	70	185 cfm 40-50 h.p.
101-160	5/16"	160	136	112	250 cfm 60-75 h.p.
161-230	3/8"	230	195	161	375 cfm 75-100 h.p.
231-317	7/16"	317	270	222	450 cfm 125 h.p.
318-400	1/2"	400	340	280	600 cfm 150 h.p.

This chart is estimated and based upon use of a long venturi nozzle, SSPC-6 commercial blast specification.

**NOZZLE PRESSURE, ABRASIVE VELOCITY AND EFFICIENCY**

Blast Nozzle Pressure	Estimated Abrasive Velocity	Estimated Efficiency Factor
140 psi	588 mph	160%
125 psi	525 mph	138%
110 psi	462 mph	115%
100 psi	420 mph	100%
95 psi	400 mph	93%
90 psi	365 mph	85%
85 psi	330 mph	78%
80 psi	270 mph	70%
75 psi	210 mph	63%
70 psi	190 mph	55%

## NOZZLE AIR AND PRESSURE REQUIREMENTS

		NOZZLE PRESSURE PSI (BAR)						
NOZZLE ORIFICE	AIR, POWER, AND ABRASIVE REQUIREMENTS	50 (3.45)	60 (4.14)	70 (4.83)	80 (5.52)	90 (6.21)	100 (6.89)	125 (8.62)
<b>1/8 inch (3.2 mm)</b>	AIR (cu ft/min) (cu m/min)	12 (0.34)	13 (0.37)	15 (0.42)	18 (0.51)	19 (0.54)	21 (0.59)	26 (0.74)
	HORSEPOWER (hp) (kW)	1.75 (1.30)	2 (1.49)	2.5 (1.86)	3 (2.24)	3.5 (2.61)	4 (2.98)	6 (4.47)
	ABRASIVE (lb/hr) (kg/hr)	70 (32)	80 (36)	90 (41)	100 (45)	110 (50)	120 (54)	135 (61)
<b>3/16 inch (4.8 mm)</b>	AIR (cu ft/min) (cu m/min)	25 (0.71)	30 (0.85)	35 (0.99)	40 (1.13)	43 (1.22)	45 (1.27)	60 (1.70)
	HORSEPOWER (hp) (kW)	5 (3.73)	8 (5.97)	9 (6.71)	9.5 (7.08)	10 (7.46)	10.5 (7.83)	16 (11.93)
	ABRASIVE (lb/hr) (kg/hr)	150 (68)	170 (77)	200 (91)	215 (98)	240 (109)	260 (118)	320 (145)
<b>1/4 inch (6.35 mm)</b>	AIR (cu ft/min) (cu m/min)	50 (1.42)	55 (1.56)	60 (1.70)	70 (1.98)	75 (2.12)	80 (2.27)	95 (2.69)
	HORSEPOWER (hp) (kW)	10 (7.46)	12 (8.95)	13 (9.69)	16 (11.93)	17 (12.68)	18 (13.42)	25 (18.64)
	ABRASIVE (lb/hr) (kg/hr)	270 (122)	300 (136)	350 (159)	400 (181)	450 (204)	500 (227)	675 (306)
<b>5/16 inch (8 mm)</b>	AIR (cu ft/min) (cu m/min)	80 (2.27)	90 (2.55)	100 (2.83)	115 (3.26)	125 (3.54)	140 (3.96)	190 (5.38)
	HORSEPOWER (hp) (kW)	17 (12.68)	20 (14.91)	25 (18.64)	27 (20.13)	28 (20.88)	30 (22.37)	36 (26.85)
	ABRASIVE (lb/hr) (kg/hr)	470 (213)	530 (240)	600 (272)	675 (306)	750 (340)	825 (374)	1000 (454)
<b>3/8 inch (9.5 mm)</b>	AIR (cu ft/min) (cu m/min)	110 (3.12)	125 (3.54)	145 (4.11)	160 (4.53)	175 (4.96)	200 (5.66)	275 (7.79)
	HORSEPOWER (hp) (kW)	25 (18.64)	29 (21.63)	32 (23.86)	35 (26.10)	40 (29.83)	45 (33.56)	57 (42.50)
	ABRASIVE (lb/hr) (kg/hr)	675 (306)	775 (352)	875 (397)	975 (442)	1060 (481)	1100 (499)	1350 (612)
<b>7/16 inch (11 mm)</b>	AIR (cu ft/min) (cu m/min)	150 (4.25)	170 (4.81)	200 (5.66)	215 (6.09)	240 (6.80)	255 (7.22)	315 (8.92)
	HORSEPOWER (hp) (kW)	35 (26.10)	40 (29.83)	45 (33.56)	50 (37.28)	55 (41.01)	60 (44.74)	70 (52.20)
	ABRASIVE (lb/hr) (kg/hr)	900 (408)	1000 (454)	1200 (544)	1300 (590)	1400 (635)	1550 (703)	1800 (816)
<b>1/2 inch (12.7 mm)</b>	AIR (cu ft/min) (cu m/min)	200 (5.66)	225 (6.37)	250 (7.08)	275 (7.79)	300 (8.50)	340 (9.63)	430 (12.18)
	HORSEPOWER (hp) (kW)	45 (33.56)	50 (37.28)	55 (41.01)	63 (46.98)	70 (52.20)	75 (55.93)	95 (70.84)
	ABRASIVE (lb/hr) (kg/hr)	1200 (544)	1350 (612)	1500 (680)	1700 (771)	1850 (839)	2025 (919)	2525 (1145)
<b>5/8 inch (16 mm)</b>	AIR (cu ft/min) (cu m/min)	300 (8.500)	350 (9.91)	400 (11.33)	450 (12.74)	500 (14.16)	550 (15.58)	700 (19.82)
	HORSEPOWER (hp) (kW)	70 (52.20)	80 (59.66)	90 (67.11)	100 (74.57)	110 (82.03)	120 (89.48)	150 (111.85)
	ABRASIVE (lb/hr) (kg/hr)	1900 (862)	2200 (998)	2400 (1089)	2700 (1225)	3000 (1361)	3300 (1497)	4000 (1814)
<b>3/4 inch (19 mm)</b>	AIR (cu ft/min) (cu m/min)	430 (12.18)	500 (14.16)	575 (16.28)	650 (18.41)	700 (19.82)	800 (22.66)	1100 (31.15)
	HORSEPOWER (hp) (kW)	100 (74.57)	115 (85.76)	130 (96.94)	145 (108.13)	160 (119.31)	175 (130.50)	215 (160.33)
	ABRASIVE (lb/hr) (kg/hr)	2700 (1225)	3100 (1406)	3500 (1588)	3900 (1769)	4300 (1950)	4700 (2132)	5700 (2586)

This table is to be used as reference only. Actual results may vary depending on specific abrasive medium used. This table is based on sand with a bulk density of 100 pounds per cubic foot.

**WHAT BORE SIZE DO YOU NEED?**

For maximum productivity, select the nozzle bore size based on the desired blast pressure and the available air pressure and flow. For example, assume you are running a 375 cfm compressor at 80% capacity. In addition to the blast cleaning nozzle, the compressor is supplying air to an air helmet and other components such as air motors and pneumatic controls, leaving 250 cfm available for the nozzle. Referring to the chart on the previous page, you can see that 250 cfm is sufficient for a 7/16" nozzle operating at 100 psi. A larger nozzle, or a worn 7/16" nozzle, will require more air flow to maintain 100 psi. This extra flow requirement will either overwork your compressor or decrease productivity. On the other hand, choosing a nozzle with a bore smaller than your compressor can supply will result in less than maximum productivity from the system.

**WHAT ARE THE BEST NOZZLE MATERIAL CHOICES?**

Nozzle material selection depends on the abrasive you choose, how often you blast, the size of the job, and the rigors of the job site. Here are general application guidelines for various materials.

**SERVICE LIFE COMPARISONS**

Approximate Service Life in Hours			
Nozzle Material	Steel Shot/Grit	Sand	Aluminum Oxide
Aluminum oxide	20-40	10-30	1-4
Tungsten carbide	500-800	300-400	20-40
Silicon carbide composite	500-800	300-400	50-100
Boron carbide	1500-2500	750-1500	200-1000

Estimated values for comparison. Actual service life will vary depending on blast pressure, media size, and particle shape.

**Aluminum oxide “alumina” nozzles** offer good service life at a lower price than other materials discussed here. They are a good choice in low usage applications where price is a primary factor and nozzle life is less important.

**Tungsten carbide nozzles** offer long life and economy when rough handling can't be avoided and mineral and coal slag abrasives are used. All tungsten carbide nozzles are not equal. Note that all Boride tungsten carbide nozzles feature top wear grade material and thick-wall construction.

**Silicon carbide composite nozzles** offer service life and durability very near tungsten carbide, but these nozzles are only about one-third the weight of tungsten carbide nozzles. Silicon carbide composite nozzles are an excellent choice when operators are on the job for long periods and prefer a lightweight nozzle.

**Boron carbide nozzles** provide longest life with optimum air and abrasive use. Boron carbide is ideal for aggressive abrasives such as aluminum oxide and selected mineral aggregates when rough handling can be avoided. Boron carbide will typically outwear tungsten carbide by five to ten times and silicon carbide by two to three times when aggressive abrasives are used.

**WHEN WET BLASTING IS A REQUIREMENT**

There are three options when wet blasting is required or desired.

First is a “water ring” attachment for standard blast nozzles that forces water on the blast stream as it exits the nozzle. While inexpensive, this option uses a lot of water and reduces the size of the blast pattern and the energy of the blast stream, cutting productivity up to 50%.

Second is a water injection system that uses a high-pressure pump to get water into the abrasive and air stream. Not only does this type of system add considerable cost and mechanical complexity, it slows air stream velocity and requires as much as six gallons of water per minute.

The third option is the WIN® water induction system from Boride. The WIN® system uses a unique nozzle configuration that takes advantage of the venturi principle to draw or induct water from a low pressure line into the abrasive and air stream. This method is much simpler than a water injection system, effective, and water consumption is reduced from up to six gallons per minute to not more than several quarts...usually less. By reducing water use you increase abrasive velocity and work speed. You enjoy a larger blasting pattern for greater production rates since WIN® nozzles incorporate a considerably larger orifice than conventional nozzles. You also gain flexibility since the WIN® system can also operate with air-only for blowdown applications or with an air/water mix for rinsing applications.

**WANT TO CUT NOZZLE REPLACEMENT COSTS 66%...OR MORE?**

Try a boron carbide replacement nozzle from Boride Products. Boron carbide replacements cost more initially, but provide you with much longer service life. Your per-hour cost with boron carbide is about one-third of the cost of cheaper nozzles.

**HOW TO GET THE MOST SERVICE LIFE OUT OF YOUR BORIDE PRODUCTS NOZZLES**

1. Avoid dropping the nozzle or banging it against anything. Nozzle materials can break.
2. Be sure to use a nozzle designed for your application and the abrasive you wish to use.
3. Always use the new gasket or washer supplied with your nozzle or nozzle insert. It can help prevent the nozzle's entry throat from being blasted away. Inspect, and replace if necessary, the gasket or washer after every 10 to 20 hours of use.
4. If you are using a Boride Products nozzle in a flanged holder, turn the nozzle a quarter turn each week. This will help to ensure more uniform wear and prolong nozzle life.

**HOW TO INSPECT, WHEN TO REPLACE**

How much wear is too much? Here are two simple tests:

1. Insert a drill bit of a size that matches the original bore of the nozzle. If there's any slop, it's time to replace it. Nozzle wear means pressure loss. Pressure loss means lost productivity —there is a 1-1/2% loss of productivity for every pound of air pressure lost.

**COMPARING NOZZLE COSTS**

(Based on approximate nozzle service life using aluminum oxide abrasive).

	<b>Boron Carbide</b>	<b>Tungsten Carbide</b>
Approximate nozzle cost	\$80	\$35
Nozzle life in hours*	200	28
Cost per hour*	\$0.40	\$1.20
<b>Cost per 200 hours</b>	\$80	\$240
Number of nozzle changeouts	1	7
<b>Cost per 400 hours</b>	\$160	\$480
Number of nozzle changeouts	2	14
<b>Cost per 600 hours</b>	\$240	\$720
Number of nozzle changeouts	3	21
<b>Cost per 800 hours</b>	\$320	\$960
Number of nozzle changeouts	4	28
<b>Cost per 1000 hours</b>	\$400	\$1200
Number of nozzle changeouts	5	35

\*Performance may vary based upon pressure, abrasive grit size and quality and other variables. These data are based on comparative testing under controlled conditions.

2. Hold an open nozzle up to the light and look down the bore. Any ripple or orange peel effect inside the carbide liner will create internal turbulence that reduces abrasive velocity. If you notice any uneven wear or pressure drop, it's time to replace.

Check the nozzle's exterior, too. The materials used to build nozzles are tough, but can be brittle. Nozzle jacketing materials are designed to help protect breakable liners from impact damage. If the jacket is cracked, chances are the liner is also cracked. If the liner is fractured, even with hairline cracks, the nozzle should be replaced immediately. It is not safe to use a cracked nozzle.

Remember that all nozzles will eventually break or wear out. Keep a supply of back-up nozzles on hand to minimize down time.



As you can see, no single nozzle can be the answer to all application requirements. Selecting the right nozzle for each job is the best way to assure work speed, quality and overall efficiency. With this in mind, a review of the Boride Products family of abrasive blasting nozzles follows.

# VENTURI NOZZLES



## LONG VENTURI NOZZLES

Long venturi style nozzles yield about a 40% greater production rate than straight bore nozzles. The internally tapered design of the venturi nozzle accelerates and evenly distributes the abrasive over the entire blast pattern. These nozzles are designed for use with a 1" I.D. blast hose for maximum cutting action on hard-to-clean surfaces.

### TUNGSTEN CARBIDE LONG VENTURI NOZZLES

#### TLVE-BRUISER® Series tungsten carbide long venturi nozzles.

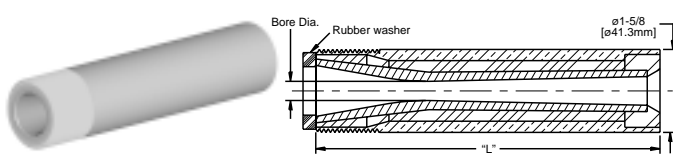

For the most physically demanding operations and greatest resistance against breakage, we recommend the top-of-the-line TLVE-Bruiser® series. This tungsten carbide nozzle features an all-brass outer body with a polyurethane inner cushion.

Venturi Bore	TLVE Series		
Thread Style	1-1/4 – 11-1/2 N.P.S.M.		
Part Number	Model Number	Bore Diameter	Length
1915630	TLVE-3	3/16" (4.8mm)	4-1/4" (108mm)
1915640	TLVE-4	1/4" (6.4mm)	5-3/8" (136.5mm)
1915650	TLVE-5	5/16" (7.9mm)	5-3/4" (146.1mm)
1915660	TLVE-6	3/8" (9.5mm)	6-3/4" (171.5mm)
1915670	TLVE-7	7/16" (11.1mm)	8" (203.2mm)
1915680	TLVE-8	1/2" (12.7mm)	9" (228.6mm)

#### TLVE-P Series tungsten carbide long venturi nozzles.

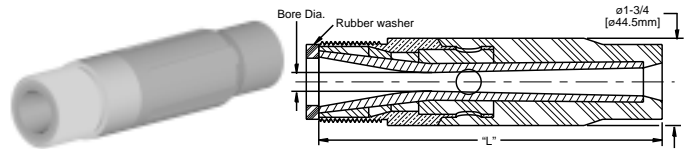

For physically demanding operations with less resistance against breakage than our top-of-the-line TLVE-BRUISER, we recommend the TLVE-P (poly series). This tungsten carbide nozzle features brass threads and a reinforced polyurethane upper body.

Venturi Bore	TLVE-P Series		
Thread Style	1-1/4 – 11-1/2 N.P.S.M.		
Part Number	Model Number	Bore Diameter	Length
2015630	TLVE-3P	3/16" (4.8mm)	4-3/8" (111.1mm)
2015640	TLVE-4P	1/4" (6.4mm)	5-1/2" (139.7mm)
2015650	TLVE-5P	5/16" (7.9mm)	5-7/8" (149.2mm)
2015660	TLVE-6P	3/8" (9.5mm)	6-7/8" (174.6mm)
2015670	TLVE-7P	7/16" (11.1mm)	8-1/8" (206.4mm)
2015680	TLVE-8P	1/2" (12.7mm)	9-1/8" (231.8mm)

**TLVE-AP Series tungsten carbide long venturi nozzles.**

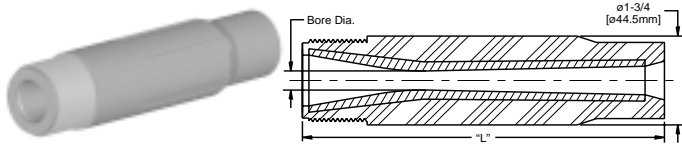

The TLVE-AP series is recommended where low price is most important. Built with polyurethane outer jacket and threads, it's competitive in price with "economy" nozzles without sacrificing the quality of a long-life tungsten carbide liner.

Venturi Bore	TLVE-AP Series		
Thread Style	1-1/4 – 11-1/2 N.P.S.M.		
Part Number	Model Number	Bore Diameter	Length
2015633	TLVE-3AP	3/16" (4.8mm)	4-1/2" (114.3mm)
2015643	TLVE-4AP	1/4" (6.4mm)	5-1/2" (139.7mm)
2015653	TLVE-5AP	5/16" (7.9mm)	6" (152.4mm)
2015663	TLVE-6AP	3/8" (9.5mm)	7" (177.8mm)
2015673	TLVE-7AP	7/16" (11.1mm)	8-1/4" (209.6mm)
2015683	TLVE-8AP	1/2" (12.7mm)	9-1/4" (235mm)

**TLVE-50 mm International Series tungsten carbide long venturi nozzles.**

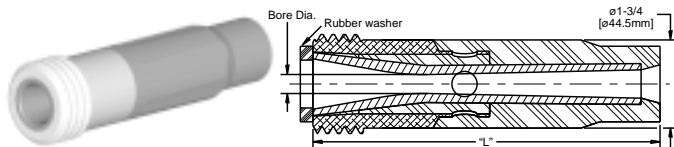

The TLVE-50mm International Series is our metric size long venturi tungsten carbide nozzle. This nozzle incorporates polyurethane jacket and 50mm 2-1/4 UNC aluminum threads, a reinforced polyurethane upper body and our tungsten carbide liner.

Venturi Bore	TLVE-50mm Series		
Thread Style	2 – 4-1/2 U.N.C.		
Part Number	Model Number	Bore Diameter	Length
2015632	TLVE-350P	3/16" (4.8mm)	4-3/8" (111.1mm)
2015642	TLVE-450P	1/4" (6.4mm)	5-1/2" (139.7mm)
2015652	TLVE-550P	5/16" (7.9mm)	5-7/8" (149.2mm)
2015662	TLVE-650P	3/8" (9.5mm)	6-7/8" (174.6mm)
2015672	TLVE-750P	7/16" (11.1mm)	8-1/8" (206.4mm)
2015682	TLVE-850P	1/2" (12.7mm)	9-1/8" (231.8mm)

**TUNGSTEN CARBIDE WIDE THROAT LONG VENTURI NOZZLES**

All of our wide throat nozzles are designed to be used with 1-1/4" I.D. blast hose. These nozzles have a 1-1/4" entry in a flanged standard 1-1/4" threaded design or 50mm 2-1/4 UNC thread. The wider throat opening in this nozzle offers a 15% increase in production over a standard venturi by eliminating restriction and turbulence upstream of the venturi section of the nozzle.

**T159 Series tungsten carbide wide throat long venturi nozzles.**

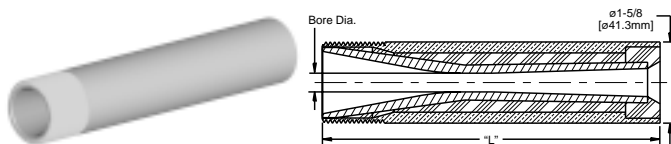

Brass outer jacket and threads, tungsten carbide liner.

Venturi Bore	T159 Series		
Thread Style	1-1/4 – 11-1/2 N.P.S.M.		
Part Number	Model Number	Bore Diameter	Length
1915950	T159-5	5/16" (7.9mm)	5-3/4" (146.1mm)
1915960	T159-6	3/8" (9.5mm)	6-3/4" (171.5mm)
1915970	T159-7	7/16" (11.1mm)	8" (203.2mm)
1915980	T159-8	1/2" (12.7mm)	9-1/8" (231.8mm)

**T159-12 venturi bore nozzles.**

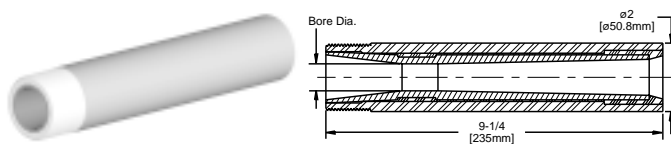

Tungsten carbide with steel jacket and threads.

Venturi Bore	T159-12		
Thread Style	1-1/2 – 11-1/2 N.P.S.M.		
Part Number	Model Number	Bore Diameter	Length
1915914	T159-12	3/4" (19.1mm)	9-1/4" (235mm)

**T159-P Series tungsten carbide wide throat long venturi nozzles.**

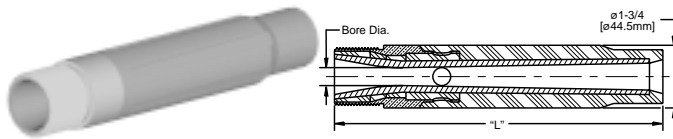

Tungsten carbide liner with polyurethane jacket and brass threads.

Venturi Bore	T159-P Series		
Thread Style	1-1/4 – 11-1/2 N.P.S.M.		
Part Number	Model Number	Bore Diameter	Length
2015950	T159-5P	5/16" (7.9mm)	5-7/8" (149.2mm)
2015960	T159-6P	3/8" (9.5mm)	6-7/8" (174.6mm)
2015970	T159-7P	7/16" (11.1mm)	8-1/8" (206.4mm)
2015980	T159-8P	1/2" (12.7mm)	9-1/8" (231.8mm)
2015910	T159-10P	5/8" (15.9mm)	9-1/4" (235mm)
2015912	T159-12P	3/4" (19.1mm)	9-1/4" (235mm)

**T159-50mm P Series tungsten carbide wide throat long venturi nozzles.**

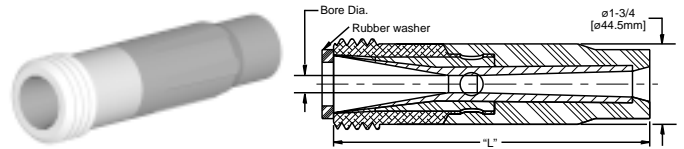

Tungsten carbide liner with polyurethane jacket and aluminum threads.

Venturi Bore	T159-50mm P Series		
Thread Style	2 – 4-1/2 U.N.C.		
Part Number	Model Number	Bore Diameter	Length
2085952	T159-550	5/16" (7.9mm)	5-7/8" (149.2mm)
2085962	T159-650	3/8" (9.5mm)	6-7/8" (174.6mm)
2085972	T159-750	7/16" (11.1mm)	8-1/8" (206.4mm)
2085982	T159-850	1/2" (12.7mm)	9" (228.6mm)
20159105	T159-1050P	5/8" (15.9mm)	9-1/4" (235mm)
20159125	T159-1250P	3/4" (19.1mm)	9-1/4" (235mm)

**T159-F Series tungsten carbide wide throat long venturi nozzles.**

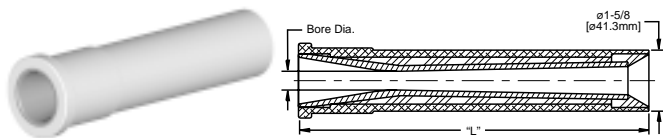

Tungsten carbide liner with flanged aluminum jacket.

Venturi Bore	T159-F Series		
Part Number	Model Number	Bore Diameter	Length
1915961	T159-6F	3/8" (9.5mm)	6-3/4" (171.5mm)
1915971	T159-7F	7/16" (11.1mm)	8" (203.2mm)
1915981	T159-8F	1/2" (12.7mm)	9-1/16" (230.2mm)
1915910	T159-10F	5/8" (15.9mm)	9-1/4" (235mm)
1915912	T159-12F	3/4" (19.1mm)	9-1/4" (235mm)

**SILICON CARBIDE COMPOSITE LONG VENTURI NOZZLES**

Boride’s exclusive silicon carbide composite is designed to replace both silicon carbide and silicon nitride. These nozzles resist breakage better than silicon carbide. Though they’re as durable as tungsten carbide, they’re lighter in weight to reduce operator fatigue.

**SCC-50mm P Series silicon carbide composite wide entry long venturi nozzles.**

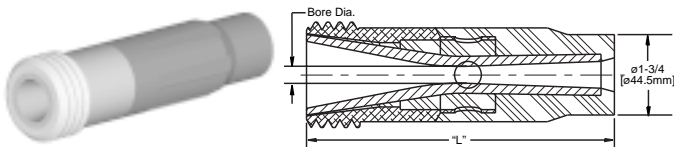

High performance wide entry long venturi design with polyurethane outer jacket and aluminum threads. Use 1" (25mm) or 1-1/4" (32mm) I.D. hose. Our most popular international style.

Wide Entry Venturi Bore	SCC-50mm P Series		
Thread Style	2 – 4-1/2 U.N.C.		
Part Number	Model Number	Bore Diameter	Length
2815932	SCC-350 P	3/16" (4.8mm)	4-3/8" (111mm)
2815942	SCC-450 P	1/4" (6.4mm)	4-1/2" (140mm)
2815952	SCC-550 P	5/16" (7.9mm)	5-7/8" (150mm)
2815962	SCC-650 P	3/8" (9.5mm)	6-7/8" (175mm)
2815972	SCC-750 P	7/16" (11.1mm)	8-1/8" (206mm)
2815982	SCC-850 P	1/2" (12.7mm)	9-1/8" (206mm)

**SCC-P Series silicon carbide composite wide entry long venturi nozzles.**

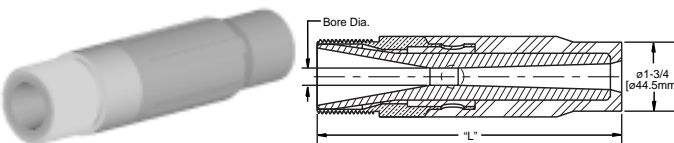

High performance wide entry long venturi design with polyurethane outer jacket and brass threads. Use 1" (25mm) or 1-1/4" (32mm) I.D. hose. Our most popular style.

Wide Entry Venturi Bore	SCC-P Series		
Thread Style	1-1/4 – 11-1/2 N.P.S.M.		
Part Number	Model Number	Bore Diameter	Length
2815930	SCC-3 P	3/16" (4.8mm)	4-3/8" (111mm)
2815940	SCC-4 P	1/4" (6.4mm)	4-1/2" (140mm)
2815950	SCC-5 P	5/16" (7.9mm)	5-7/8" (150mm)
2815960	SCC-6 P	3/8" (9.5mm)	6-7/8" (175mm)
2815970	SCC-7 P	7/16" (11.1mm)	8-1/8" (206mm)
2815980	SCC-8 P	1/2" (12.7mm)	9-1/8" (206mm)

**SCC-50mm AP Series silicon carbide composite wide entry long venturi nozzles.**

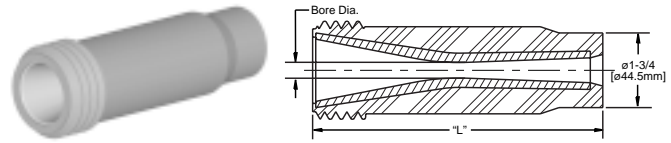

High performance wide entry long venturi design with all-polyurethane outer jacket and threads. Use 1" (25mm) or 1-1/4" (32mm) I.D. hose.

Wide Entry Venturi Bore	SCC-50mm AP Series		
Thread Style	2 – 4-1/2 U.N.C.		
Part Number	Model Number	Bore Diameter	Length
2815934	SCC-350 AP	3/16" (4.8mm)	4-3/8" (111mm)
2815944	SCC-450 AP	1/4" (6.4mm)	4-1/2" (140mm)
2815954	SCC-550 AP	5/16" (7.9mm)	5-7/8" (150mm)
2815964	SCC-650 AP	3/8" (9.5mm)	6-7/8" (175mm)
2815974	SCC-750 AP	7/16" (11.1mm)	8-1/8" (206mm)
2815984	SCC-850 AP	1/2" (12.7mm)	9-1/8" (206mm)

**SCC-AP Series silicon carbide composite wide entry long venturi nozzles.**

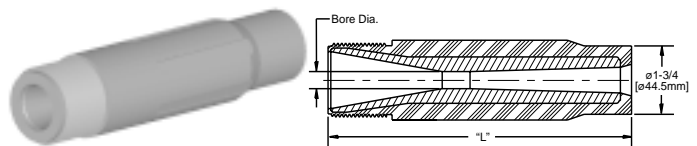

High performance wide entry long venturi design with all-polyurethane outer jacket and threads. Use 1" (25mm) or 1-1/4" (32mm) I.D. hose. Our lightest-weight style.

Wide Entry Venturi Bore	SCC-AP Series		
Thread Style	1-1/4 – 11-1/2 N.P.S.M.		
Part Number	Model Number	Bore Diameter	Length
2815933	SCC-3 AP	3/16" (4.8mm)	4-3/8" (111mm)
2815943	SCC-4 AP	1/4" (6.4mm)	4-1/2" (140mm)
2815953	SCC-5 AP	5/16" (7.9mm)	5-7/8" (150mm)
2815963	SCC-6 AP	3/8" (9.5mm)	6-7/8" (175mm)
2815973	SCC-7 AP	7/16" (11.1mm)	8-1/8" (206mm)
2815983	SCC-8 AP	1/2" (12.7mm)	9-1/8" (206mm)

### BORON CARBIDE LONG VENTURI NOZZLES

Boron carbide nozzles offer the longest wear life of any standard nozzle material. Peak nozzle production performance is maintained for longer periods with optimum consumption of air and abrasive. Boron carbide nozzles typically outwear tungsten carbide nozzles by five to ten times and silicon carbide by two to three times. Boron carbide nozzles are recommended for use with abrasives such as aluminum oxide and aggressive mineral aggregates.

#### BLVE Series boron carbide long venturi nozzles.

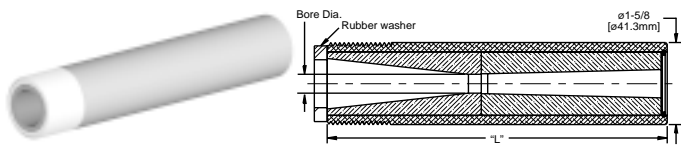

This nozzle is designed for jobs where the nozzle is generally held 18 or more inches away from the surface being blasted. For high production jobs—expect longer nozzle life. Aluminum jacket and threads.

Venturi Bore	BLVE Series		
Thread Style	1-1/4 – 11-1/2 N.P.S.M.		
Part Number	Model Number	Bore Diameter	Length
1510045	BLVE-4	1/4" (6.4mm)	5-1/4" (133.4mm)
1510056	BLVE-5	5/16" (7.9mm)	5-1/2" (139.7mm)
1510067	BLVE-6	3/8" (9.5mm)	6-1/2" (165.1mm)
1510078	BLVE-7	7/16" (11.1mm)	7-7/8" (200mm)
1510089	BLVE-8	1/2" (12.7mm)	8-5/8" (219mm)

#### BLVE-P Series boron carbide long venturi nozzles.

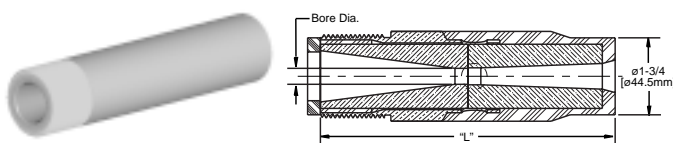

High performance long venturi style with 1" entry bore, polyurethane jacket and brass threads.

Venturi Bore	BLVE-P Series		
Thread Style	1-1/4 – 11-1/2 N.P.S.M.		
Part Number	Model Number	Bore Diameter	Length
1510245	BLVE-4 P	1/4" (6.4mm)	5-1/4" (133.4mm)
1510256	BLVE-5 P	5/16" (7.9mm)	5-1/2" (139.7mm)
—	BLVE-6 P	3/8" (9.5mm)	6-1/2" (165.1mm)
—	BLVE-7 P	7/16" (11.1mm)	7-7/8" (200mm)
—	BLVE-8 P	1/2" (12.7mm)	8-5/8" (219mm)

#### BLVE-AP Series boron carbide long venturi nozzles.

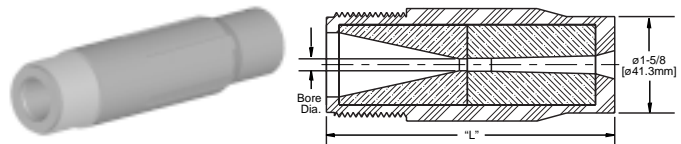

High performance long venturi style with 1" entry bore, all-polyurethane jacket and threads.

Venturi Bore	BLVE-AP Series		
Thread Style	1-1/4 – 11-1/2 N.P.S.M.		
Part Number	Model Number	Bore Diameter	Length
—	BLVE-4 AP	1/4" (6.4mm)	5-1/4" (133.4mm)
—	BLVE-5 AP	5/16" (7.9mm)	5-1/2" (139.7mm)
—	BLVE-6 AP	3/8" (9.5mm)	6-1/2" (165.1mm)
—	BLVE-7 AP	7/16" (11.1mm)	7-7/8" (200mm)
—	BLVE-8 AP	1/2" (12.7mm)	8-5/8" (219mm)

#### BLVE-50mm Series boron carbide long venturi nozzles.

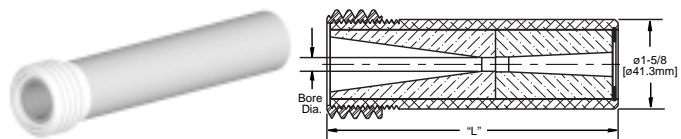

High performance long venturi style with 1" entry bore, 50mm aluminum threads and jacket.

Venturi Bore	BLVE-50mm Series		
Thread Style	2 – 4-1/2 U.N.C.		
Part Number	Model Number	Bore Diameter	Length
1510145	BLVE-450	1/4" (6.4mm)	5-1/4" (133.4mm)
1510156	BLVE-550	5/16" (7.9mm)	5-1/2" (139.7mm)
1510167	BLVE-650	3/8" (9.5mm)	6-1/2" (165.1mm)
1510178	BLVE-750	7/16" (11.1mm)	7-7/8" (200mm)
1510189	BLVE-850	1/2" (12.7mm)	8-5/8" (219mm)

## MEDIUM LENGTH VENTURI NOZZLES

Medium length venturi nozzles are most effective on jobs where the nozzles are held close to the surface being blasted (18 inches or less).

### TUNGSTEN CARBIDE MEDIUM LENGTH VENTURI NOZZLES

**T120 Single Outlet Series tungsten carbide venturi nozzles.**

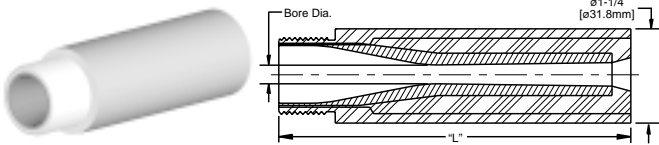

Tungsten carbide with steel outer jacket and thread construction. Excellent for use with spin blasters and pressure cabinets.

Venturi Bore	T120 Series		
Thread Style	3/4 – 14 N.P.S.M.		
Part Number	Model Number	Bore Diameter	Length
1912030	T120-3	3/16" (4.8mm)	3-1/2" (88.9mm)
1912040	T120-4	1/4" (6.4mm)	4-11/16" (119.1mm)

### BORON CARBIDE MEDIUM LENGTH VENTURI NOZZLES

**D Series boron carbide medium length venturi nozzles.**

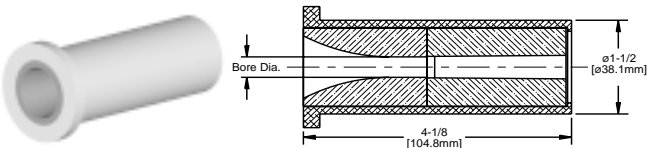

Boron carbide liner with flanged aluminum jacket.

Venturi Bore	D Series		
Part Number	Model Number	Bore Diameter	Length
1502034	B3M4-D	3/16" (4.8mm)	4-1/8" (104.8mm)
1502044	B4M4-D	1/4" (6.4mm)	4-1/8" (104.8mm)
1502054	B5M4-D	5/16" (7.9mm)	4-1/8" (104.8mm)
1502064	B6M4-D	3/8" (9.5mm)	4-1/8" (104.8mm)

**F Series boron carbide medium length venturi nozzles.**

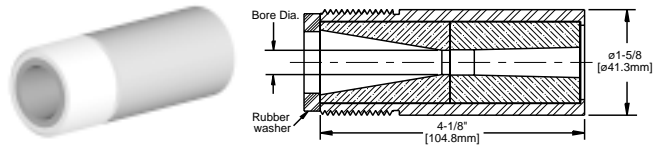

Boron carbide liner with steel jacket and threads with black oxide coating.

Venturi Bore	F Series		
Thread Style	1-1/4 – 11-1/2 N.P.S.M.		
Part Number	Model Number	Bore Diameter	Length
1504034	B3M4-F	3/16" (4.8mm)	4-1/8" (104.8mm)
1504044	B4M4-F	1/4" (6.4mm)	4-1/8" (104.8mm)
1504054	B5M4-F	5/16" (7.9mm)	4-1/8" (104.8mm)
1504064	B6M4-F	3/8" (9.5mm)	4-1/8" (104.8mm)
1504074	B7M4-F	7/16" (11.1mm)	4-1/8" (104.8mm)
1504084	B8M4-F	1/2" (12.7mm)	4-1/8" (104.8mm)
1504184	B8M4-F50mm	1/2" (12.7mm)	4" (101.6mm)

**F-AP Series boron carbide medium length venturi nozzles.**

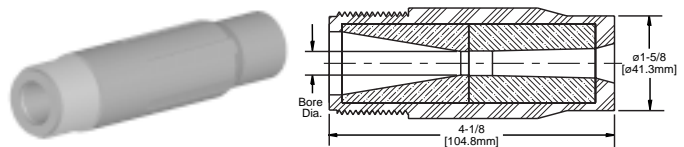

Boron carbide liner with polyurethane jacket and threads.

Venturi Bore	F-AP Series		
Thread Style	1-1/4 – 11-1/2 N.P.S.M.		
Part Number	Model Number	Bore Diameter	Length
1504035	B3M4-FAP	3/16" (4.8mm)	4-1/8" (104.8mm)
1504045	B4M4-FAP	1/4" (6.4mm)	4-1/8" (104.8mm)
1504055	B5M4-FAP	5/16" (7.9mm)	4-1/8" (104.8mm)
1504065	B6M4-FAP	3/8" (9.5mm)	4-1/8" (104.8mm)

**K Series boron carbide medium length venturi nozzles.**

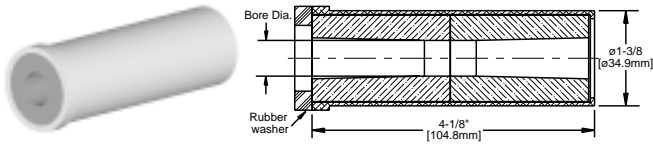

Boron carbide liner with flanged aluminum jacket.

Venturi Bore		K Series	
Part Number	Model Number	Bore Diameter	Length
1508034	B3M4-K	3/16" (4.8mm)	4-1/8" (104.8mm)
1508044	B4M4-K	1/4" (6.4mm)	4-1/8" (104.8mm)
1508054	B5M4-K	5/16" (7.9mm)	4-1/8" (104.8mm)
1508064	B6M4-K	3/8" (9.5mm)	4-1/8" (104.8mm)
1508074	B7M4-K	7/16" (11.1mm)	4-1/8" (104.8mm)
1508084	B8M4-K	1/2" (12.7mm)	4-1/8" (104.8mm)



## SHORT VENTURI NOZZLES

Short venturi nozzles offer the widest possible pattern at close range.

Use these nozzles when blasting 12" or less from the surface.

### TUNGSTEN CARBIDE SHORT VENTURI NOZZLES

#### TL108 Series tungsten carbide short venturi nozzles.

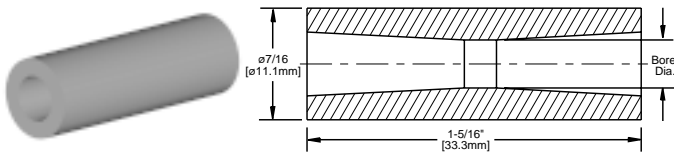

All tungsten carbide short venturi design. 7/16" O.D. Insert

Nozzle Insert	TL108 Series		
Part Number	Model Number	Bore Diameter	Length
1710821	TL108-2	1/8" (3.4mm)	1-5/16" (33.3mm)
1710831	TL108-3	3/16" (4.8mm)	1-5/16" (33.3mm)
1710841	TL108-4	1/4" (6.4mm)	1-5/16" (33.3mm)

#### T121 Series tungsten carbide short venturi nozzles.

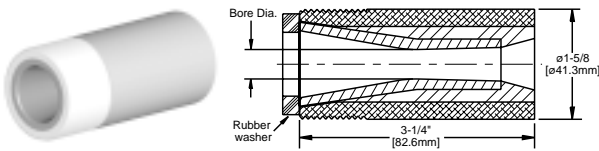

Tungsten carbide liner with aluminum jacket and threads.

Venturi Bore	T121 Series		
Thread Style	1-1/4 – 11-1/2 N.P.S.M.		
Part Number	Model Number	Bore Diameter	Length
1912130	T121-3	3/16" (4.8mm)	3-1/4" (82.6mm)
1912140	T121-4	1/4" (6.4mm)	3-1/4" (82.6mm)
1912150	T121-5	5/16" (7.9mm)	3-1/4" (82.6mm)
1912160	T121-6	3/8" (9.5mm)	3-1/4" (82.6mm)
1912170	T121-7	7/16" (11.1mm)	3-1/4" (82.6mm)
1912180	T121-8	1/2" (12.7mm)	3-1/4" (82.6mm)
—	T121-10	5/8" (15.9mm)	3-1/4" (82.6mm)
1912112	T121-12	3/4" (19.1mm)	3-1/4" (82.6mm)

#### T121-AP Series tungsten carbide short venturi nozzles.

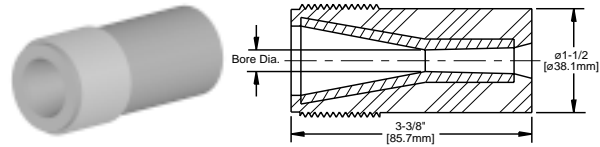

Tungsten carbide with polyurethane jacket and threads.

Venturi Bore	T121-AP Series		
Thread Style	1-1/4 – 11-1/2 N.P.S.M.		
Part Number	Model Number	Bore Diameter	Length
2082133	T121-3AP	3/16" (4.8mm)	3-3/8" (85.7mm)
2082143	T121-4AP	1/4" (6.4mm)	3-3/8" (85.7mm)
2082153	T121-5AP	5/16" (7.9mm)	3-3/8" (85.7mm)
2082163	T121-6AP	3/8" (9.5mm)	3-3/8" (85.7mm)
2082173	T121-7AP	7/16" (11.1mm)	3-3/8" (85.7mm)
2082183	T121-8AP	1/2" (12.7mm)	3-3/8" (85.7mm)
—	T121-10AP	5/8" (15.9mm)	3-3/8" (85.7mm)
2082114	T121-12AP	3/4" (19.1mm)	3-3/8" (85.7mm)

#### T121-P Series tungsten carbide short venturi nozzles.

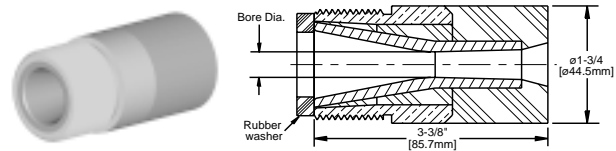

Tungsten carbide liner with polyurethane jacket and brass threads.

Venturi Bore	T121-P Series		
Thread Style	1-1/4 – 11-1/2 N.P.S.M.		
Part Number	Model Number	Bore Diameter	Length
2082130	T121-3P	3/16" (4.8mm)	3-3/8" (85.7mm)
2082140	T121-4P	1/4" (6.4mm)	3-3/8" (85.7mm)
2082150	T121-5P	5/16" (7.9mm)	3-3/8" (85.7mm)
2082160	T121-6P	3/8" (9.5mm)	3-3/8" (85.7mm)
2082170	T121-7P	7/16" (11.1mm)	3-3/8" (85.7mm)
2082180	T121-8P	1/2" (12.7mm)	3-3/8" (85.7mm)
—	T121-10P	5/8" (15.9mm)	3-3/8" (85.7mm)

**T121-50mm Series tungsten carbide short venturi nozzles.**

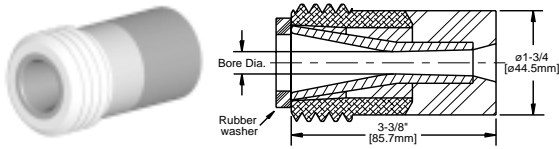

Tungsten carbide with a polyurethane jacket and aluminum threads.

Venturi Bore	T121-50mm Series		
Thread Style	2 – 4-1/2 U.N.C.		
Part Number	Model Number	Bore Diameter	Length
2082132	T121-350	3/16" (4.8mm)	3-3/8" (85.7mm)
2082142	T121-450	1/4" (6.4mm)	3-3/8" (85.7mm)
2082152	T121-550	5/16" (7.9mm)	3-3/8" (85.7mm)
2082162	T121-650	3/8" (9.5mm)	3-3/8" (85.7mm)
2082172	T121-750	7/16" (11.1mm)	3-3/8" (85.7mm)
2082182	T121-850	1/2" (12.7mm)	3-3/8" (85.7mm)
—	T121-1050	5/8" (15.9mm)	3-3/8" (85.7mm)
—	T121-1250	3/4" (19.1mm)	3-3/8" (85.7mm)

**T121-50mm AP Series tungsten carbide short venturi nozzles.**

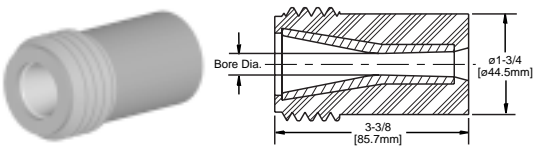

Tungsten carbide nozzle with polyurethane jacket and threads.

Venturi Bore	T121-50mm AP Series		
Thread Style	2 – 4-1/2 U.N.C.		
Part Number	Model Number	Bore Diameter	Length
—	T121-350AP	3/16" (4.8mm)	3-3/8" (85.7mm)
—	T121-450AP	1/4" (6.4mm)	3-3/8" (85.7mm)
—	T121-550AP	5/16" (7.9mm)	3-3/8" (85.7mm)
—	T121-650AP	3/8" (9.5mm)	3-3/8" (85.7mm)
—	T121-750AP	7/16" (11.1mm)	3-3/8" (85.7mm)
—	T121-850AP	1/2" (12.7mm)	3-3/8" (85.7mm)
—	T121-1050AP	5/8" (15.9mm)	3-3/8" (85.7mm)
—	T121-1250AP	3/4" (19.1mm)	3-3/8" (85.7mm)

**BORON CARBIDE SHORT VENTURI NOZZLES**

**GV Series boron carbide short venturi nozzles.**

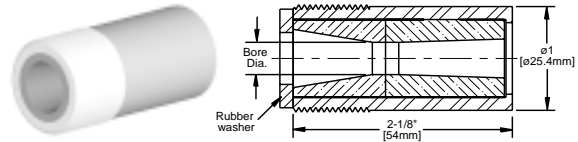

Boron carbide with steel jacket and threads.

Straight Bore	GV Series		
Thread Style	3/4 – 14 N.P.S.M.		
Part Number	Model Number	Bore Diameter	Length
1505532	B3S2-GV	3/16" (4.8mm)	2-1/8" (54mm)
1505542	B4S2-GV	1/4" (6.4mm)	2-1/8" (54mm)
1505552	B5S2-GV	5/16" (7.9mm)	2-1/8" (54mm)
1505562	B6S2-GV	3/8" (9.5mm)	2-1/8" (54mm)

**LV Series boron carbide short venturi nozzles.**

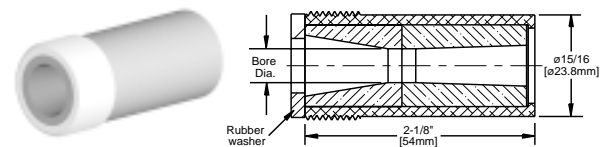

Boron carbide with an aluminum jacket and threads.

Venturi Bore	LV Series		
Thread Style	1 – 14 U.N.S.		
Part Number	Model Number	Bore Diameter	Length
1509532	B3S2-LV	3/16" (4.8mm)	2-1/8" (54mm)
1509542	B4S2-LV	1/4" (6.4mm)	2-1/8" (54mm)
1509552	B5S2-LV	5/16" (7.9mm)	2-1/8" (54mm)
1509562	B6S2-LV	3/8" (9.5mm)	2-1/8" (54mm)

# SPECIAL VENTURI BORE PRODUCTS



## DOUBLE VENTURI NOZZLES

The double venturi offers a 35% larger blast pattern than a standard long venturi with only a very slight loss in abrasive velocity. Designed to be used on jobs where medium cutting action is required with a more even dispersion of abrasive throughout the larger blast pattern. Excellent for plastic or agricultural abrasives.

### TUNGSTEN CARBIDE DOUBLE VENTURI NOZZLES

#### T125 Series tungsten carbide double venturi nozzles.

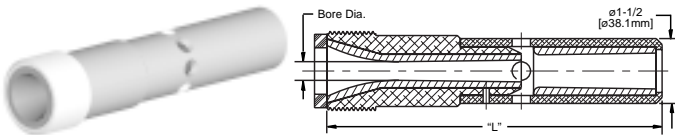

Tungsten carbide with steel jacket and aluminum threads.

Double Venturi Bore	T125 Series		
Thread Style	1-1/4 – 11-1/2 N.P.S.M.		
Part Number	Model Number	Bore Diameter	Length
1912530	T125-3	3/16" (4.8mm)	5" (127mm)
1912540	T125-4	1/4" (6.4mm)	5-7/8" (149.2mm)
1912550	T125-5	5/16" (7.9mm)	6-5/16" (160.3mm)
1912560	T125-6	3/8" (9.5mm)	6-7/8" (174.6mm)
1912570	T125-7	7/16" (11.1mm)	8-1/2" (215.9mm)
1912580	T125-8	1/2" (12.7mm)	9-1/4" (235mm)

### SILICON CARBIDE COMPOSITE DOUBLE VENTURI NOZZLES

#### SCC 125 Series silicon carbide composite double venturi nozzles.

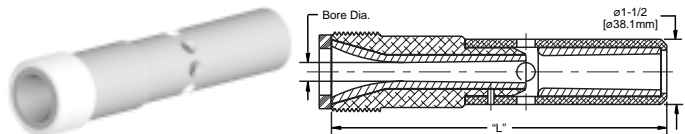

Silicon carbide composite nozzle with aluminum jacket and threads.

Double Venturi Bore	SCC 125 Series		
Thread Style	1-1/4 – 11-1/2 N.P.S.M.		
Part Number	Model Number	Bore Diameter	Length
BE98200A	SCC 125-6	3/8" (9.5mm)	6-7/8" (174.6mm)
BE98200B	SCC 125-8	1/2" (12.7mm)	9-1/4" (235mm)

#### T125-50mm Series double venturi nozzles.

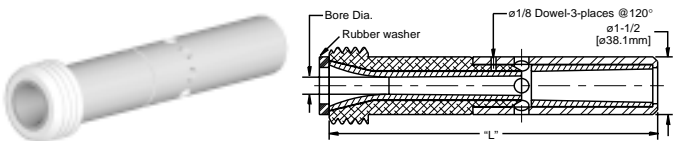

Tungsten carbide with aluminum jacket and threads.

Double Venturi Bore	T125-50mm Series		
Thread Style	2 – 4-1/2 U.N.C.		
Part Number	Model Number	Bore Diameter	Length
1912543	T125-450	1/4" (6.4mm)	5-7/8" (149.2mm)
1912553	T125-550	5/16" (7.9mm)	6-5/16" (160.3mm)
1912563	T125-650	3/8" (9.5mm)	6-7/8" (174.6mm)
1912573	T125-750	7/16" (11.1mm)	8-1/2" (215.9mm)
1912583	T125-850	1/2" (12.7mm)	9-1/4" (235mm)

#### SCC 125-50mm Series silicon carbide composite double venturi nozzles.

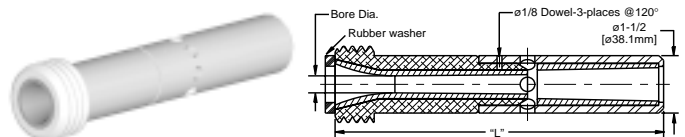

Silicon carbide composite nozzle with aluminum jacket and aluminum metric threads.

Double Venturi Bore	SCC 125-50mm Series		
Thread Style	2 – 4-1/2 U.N.C.		
Part Number	Model Number	Bore Diameter	Length
BE98200P	SCC 125-650	3/8" (9.5mm)	6-7/8" (174.6mm)
BE98200N	SCC 125-850	1/2" (12.7mm)	9-1/4" (235mm)

**BAZOOKA® NOZZLES**

**T159-VP Series tungsten carbide BAZOOKA® nozzles.**

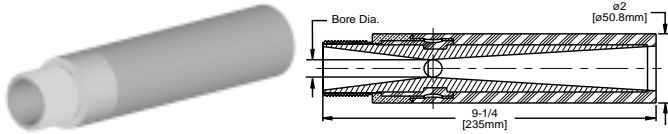

For white metal or near white metal blast use at 125 to 150 psi nozzle pressure. For commercial or sweep blast use at 90 to 100 psi nozzle pressure. The BAZOOKA yields a 60% larger pattern with minimal operator fatigue. Tungsten carbide liner with polyurethane jacket and brass threads.

Venturi Bore	T159-VP Series		
Thread Style	1-1/4 – 11-1/2 N.P.S.M.		
Part Number	Model Number	Bore Diameter	Length
2015940V	T159-4VP	1/4" (6.4mm)	9-1/4" (235mm)
2015960V	T159-6VP	3/8" (9.5mm)	9-1/4" (235mm)
2015970V	T159-7VP	7/16" (11.1mm)	9-1/4" (235mm)
2015980V	T159-8VP	1/2" (12.7mm)	9-1/4" (235mm)
2015912V	T159-12VP	3/4" (19.1mm)	9-1/4" (235mm)

**T159-50mmVP Series tungsten carbide BAZOOKA® nozzles.**

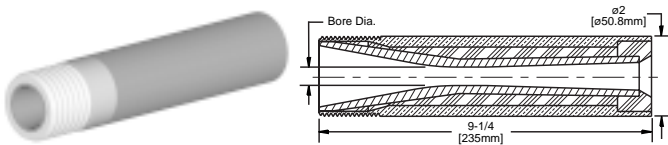

Tungsten carbide liner with polyurethane jacket and brass threads.

Venturi Bore	T159-50mm VP Series		
Thread Style	2 – 4-1/2 U.N.C.		
Part Number	Model Number	Bore Diameter	Length
2015961	T159-650VP	3/8" (9.5mm)	9-1/4" (235mm)
2015971	T159-750VP	7/16" (11.1mm)	9-1/4" (235mm)
2015981	T159-850VP	1/2" (12.7mm)	9-1/4" (235mm)
2015913	T159-1250VP	3/4" (19.1mm)	9-1/4" (235mm)

**TUNGSTEN CARBIDE VENTURI HOSE INSERTS**

**T132 Single Outlet Series tungsten carbide hose insert nozzles.**

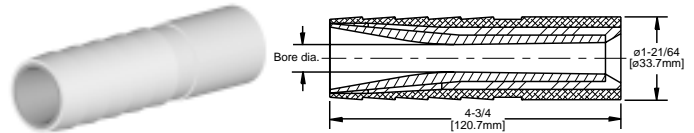

Tungsten carbide liner with aluminum jacket. Designed for use with 1-1/4" (32mm) I.D. hose.

Hose Nozzles	T132 Series		
Part Number	Model Number	Bore Diameter	Length
1913250	T132-5	5/16" (7.9mm)	4-3/4" (120.7mm)
1913260	T132-6	3/8" (9.5mm)	4-3/4" (120.7mm)
1913270	T132-7	7/16" (11.1mm)	4-3/4" (120.7mm)
1913280	T132-8	1/2" (12.7mm)	4-3/4" (120.7mm)

# STRAIGHT BORE NOZZLES



## LONG STRAIGHT BORE NOZZLES

Long straight bore nozzles are made for close range spot blasting. With small blast patterns and little overblast, they are good for cleaning small areas: weldments, grillwork, railings.

### TUNGSTEN CARBIDE LONG STRAIGHT BORE NOZZLES

#### T101 Single Outlet Series tungsten carbide straight bore nozzles.

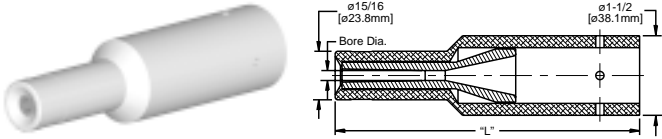

Aluminum outer jacket. Slip-on assembly (coupled mount).

Straight Nozzles	T101 Series		
Part Number	Model Number	Bore Diameter	Length
1910130	T101-3	3/16" (4.8mm)	5-3/4" (146.1mm)
1910140	T101-4	1/4" (6.4mm)	7-3/8" (187.3mm)

#### T123-AP Series straight bore nozzles.

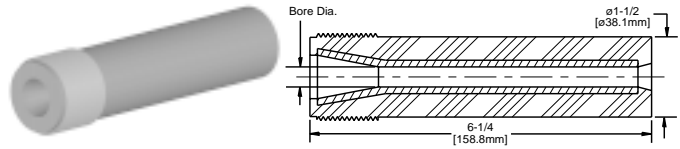

Tungsten carbide liner with polyurethane jacket and threads.

Straight Bore	T123-AP Series		
Thread Style	1-1/4 – 11-1/2 N.P.S.M.		
Part Number	Model Number	Bore Diameter	Length
2082333	T123-3AP	3/16" (4.8mm)	6-1/4" (158.8mm)
2082343	T123-4AP	1/4" (6.4mm)	6-1/4" (158.8mm)
2082353	T123-5AP	5/16" (7.9mm)	6-1/4" (158.8mm)
2082363	T123-6AP	3/8" (9.5mm)	6-1/4" (158.8mm)
2082373	T123-7AP	7/16" (11.1mm)	6-1/4" (158.8mm)
2082383	T123-8AP	1/2" (12.7mm)	6-1/4" (158.8mm)

#### T123 Series tungsten carbide long straight bore nozzles.

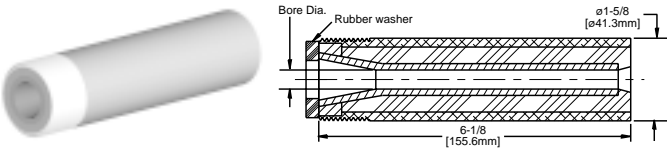

Use for spot blasting or blasting weldments. This nozzle produces a small tight pattern with little overblast. Tungsten carbide with aluminum jacket and threads.

Straight Bore	T123 Series		
Thread Style	1-1/4 – 11-1/2 N.P.S.M.		
Part Number	Model Number	Bore Diameter	Length
1912330	T123-3	3/16" (4.8mm)	6-1/8" (155.6mm)
1912340	T123-4	1/4" (6.4mm)	6-1/8" (155.6mm)
1912350	T123-5	5/16" (7.9mm)	6-1/8" (155.6mm)
1912360	T123-6	3/8" (9.5mm)	6-1/8" (155.6mm)
1912370	T123-7	7/16" (11.1mm)	6-1/8" (155.6mm)
1912380	T123-8	1/2" (12.7mm)	6-1/8" (155.6mm)

### BORON CARBIDE LONG STRAIGHT BORE NOZZLES

#### B Series (4" length) boron carbide straight bore nozzles.

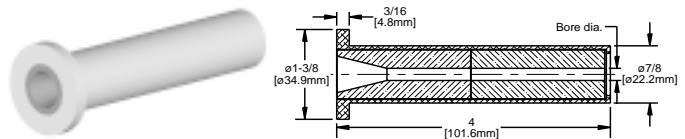

Boron carbide with flanged aluminum jacket.

Straight Bore	B Series		
Part Number	Model Number	Bore Diameter	Length
1501024	B2L4-B	1/8" (3.4mm)	4" (101.6mm)
1501034	B3L4-B	3/16" (4.8mm)	4" (101.6mm)
1501044	B4L4-B	1/4" (6.4mm)	4" (101.6mm)

**B Series (6" length) boron carbide straight bore nozzles.**

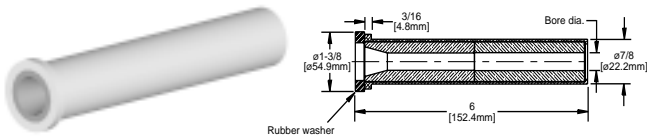

Boron carbide with flanged aluminum jacket.

Straight Bore	B Series		
Part Number	Model Number	Bore Diameter	Length
1501056	B5L6-B	5/16" (7.9mm)	6" (152.4mm)
1501066	B6L6-B	3/8" (9.5mm)	6" (152.4mm)
1501076	B7L6-B	7/16" (11.1mm)	6" (152.4mm)
1501086	B8L6-B	1/2" (12.7mm)	6" (152.4mm)

**H Series boron carbide straight bore nozzles.**

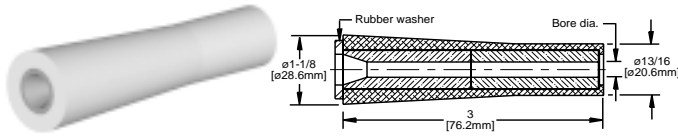

Boron carbide with aluminum jacket.

Straight Bore	H Series		
Part Number	Model Number	Bore Diameter	Length
1506024	B2L4-4	1/8" (3.4mm)	4" (101.6mm)
15060241	B2-1/2L4-H	5/32" (4mm)	4" (101.6mm)
1506034	B3L4-H	3/16" (4.8mm)	4" (101.6mm)
1506044	B4L4-H	1/4" (6.4mm)	4" (101.6mm)

**E Series (6-1/8" length) boron carbide straight bore nozzles.**

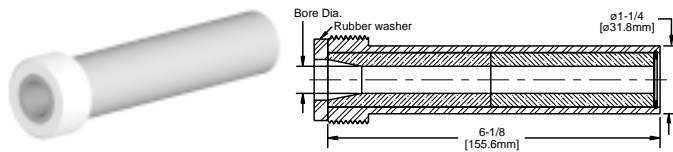

Boron carbide with steel jacket and threads.

Straight Bore	E Series		
Thread Style	1-1/4" - 11-1/2" N.P.S.M.		
Part Number	Model Number	Bore Diameter	Length
1503046	B4L6-E	1/4" (6.4mm)	6-1/8" (155.6mm)
1503056	B5L6-E	5/16" (7.9mm)	6-1/8" (155.6mm)
1503066	B6L6-E	3/8" (9.5mm)	6-1/8" (155.6mm)
1503076	B7L6-E	7/16" (11.1mm)	6-1/8" (155.6mm)
1503086	B8L6-E	1/2" (12.7mm)	6-1/8" (155.6mm)

**J Series boron carbide straight bore nozzles.**

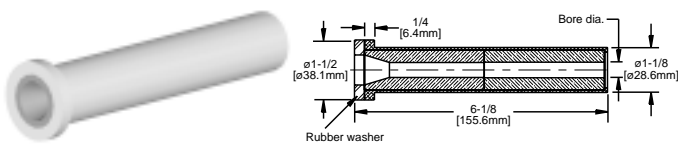

Boron carbide with flanged aluminum jacket.

Straight Bore	J Series		
Part Number	Model Number	Bore Diameter	Length
1507046	B4L6-J	1/4" (6.4mm)	6-1/8" (155.6mm)
1507056	B5L6-J	5/16" (7.9mm)	6-1/8" (155.6mm)
1507066	B6L6-J	3/8" (9.5mm)	6-1/8" (155.6mm)
1507086	B8L6-J	1/2" (12.7mm)	6-1/8" (155.6mm)

## MEDIUM STRAIGHT BORE NOZZLES

### ALUMINUM OXIDE (CERAMIC) MEDIUM STRAIGHT BORE NOZZLES

Boride Products supplies a full line of premium grade aluminum oxide ceramic nozzles for immediate delivery. If your equipment calls for a non-standard nozzle design, we can produce it for you. For special needs, contact us.

#### C1 Series aluminum oxide ceramic sandblasting straight bore inserts.

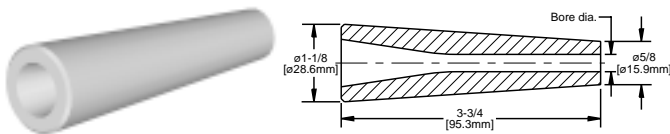

1-1/8" O.D., tapered to 5/8" O.D.

Straight Bore	C1 Series		
Part Number	Model Number	Bore Diameter	Length
1213010	C1-1	3/32" (2.4mm)	3-3/4" (95.3mm)
1213020	C1-2	1/8" (3.2mm)	3-3/4" (95.3mm)
1213025	C1-2-1/2	5/32" (4mm)	3-3/4" (95.3mm)
1213030	C1-3	3/16" (4.8mm)	3-3/4" (95.3mm)
1213040	C1-4	1/4" (6.4mm)	3-3/4" (95.3mm)
1213050	C1-5	5/16" (7.9mm)	3-3/4" (95.3mm)
1213060	C1-6	3/8" (9.5mm)	3-3/4" (95.3mm)

#### CB Series aluminum oxide ceramic sandblasting straight bore inserts.

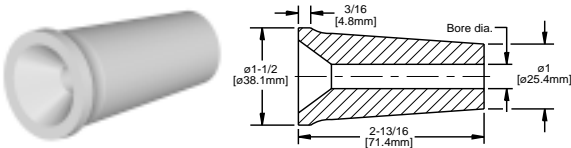

1-1/2" O.D. flange, tapered to 1" O.D.

Straight Bore	CB Series		
Part Number	Model Number	Bore Diameter	Length
1215040	CB-4	1/4" (6.4mm)	2-13/16" (71.4mm)
1215060	CB-6	3/8" (9.5mm)	2-13/16" (71.4mm)
1215080	CB-8	1/2" (12.7mm)	2-13/16" (71.4mm)

### TUNGSTEN CARBIDE MEDIUM STRAIGHT BORE NOZZLES

#### T122-P Series tungsten carbide straight bore nozzles.

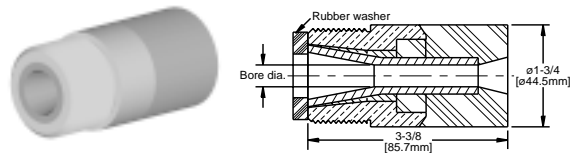

Tungsten carbide liner with polyurethane jacket and brass threads.

Straight Bore	T122-P Series		
Thread Style	1-1/4 – 11-1/2 N.P.S.M.		
Part Number	Model Number	Bore Diameter	Length
2082230	T122-3P	3/16" (4.8mm)	3-3/8" (85.7mm)
2082240	T122-4P	1/4" (6.4mm)	3-3/8" (85.7mm)
2082250	T122-5P	5/16" (7.9mm)	3-3/8" (85.7mm)
2082260	T122-6P	3/8" (9.5mm)	3-3/8" (85.7mm)
2082270	T122-7P	7/16" (11.1mm)	3-3/8" (85.7mm)
2082280	T122-8P	1/2" (12.7mm)	3-3/8" (85.7mm)

#### T122-AP Series straight bore nozzles.

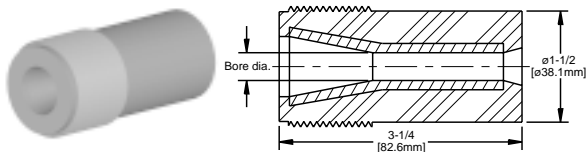

Tungsten carbide liner with polyurethane jacket and threads.

Straight Bore	T122-AP Series		
Thread Style	1-1/4 – 11-1/2 N.P.S.M.		
Part Number	Model Number	Bore Diameter	Length
2082233	T122-3AP	3/16" (4.8mm)	3-1/4" (82.6mm)
2082243	T122-4AP	1/4" (6.4mm)	3-1/4" (82.6mm)
2082253	T122-5AP	5/16" (7.9mm)	3-1/4" (82.6mm)
2082260	T122-6AP	3/8" (9.5mm)	3-1/4" (82.6mm)
2082273	T122-7AP	7/16" (11.1mm)	3-1/4" (82.6mm)
2082283	T122-8AP	1/2" (12.7mm)	3-1/4" (82.6mm)

**T222 Series tungsten carbide straight bore mid-flange nozzles.**

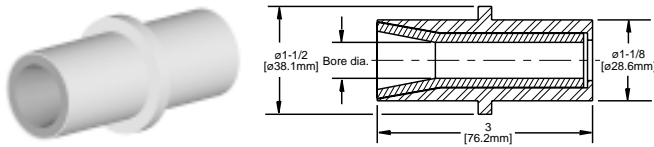

Tungsten carbide with steel outer jacket and 1-1/2" middle flange.

Mid Flange	T222 Series		
Part Number	Model Number	Bore Diameter	Length
1922260	T222-6	3/8" (9.5mm)	3" (76.2mm)
1922280	T222-8	1/2" (12.7mm)	3" (76.2mm)

**TL170 Tungsten carbide straight bore nozzle.**

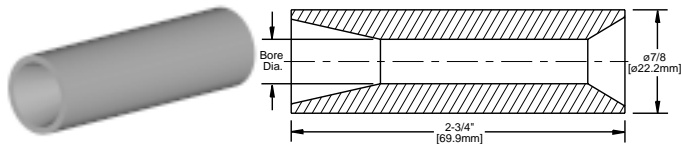

7/8" O.D. insert.

Nozzle Insert	TL170		
Part Number	Model Number	Bore Diameter	Length
1717061	TL170-6	3/8" (9.5mm)	2-3/4" (69.9mm)

**BORON CARBIDE MEDIUM STRAIGHT BORE NOZZLES**

**B Series boron carbide straight bore nozzles.**

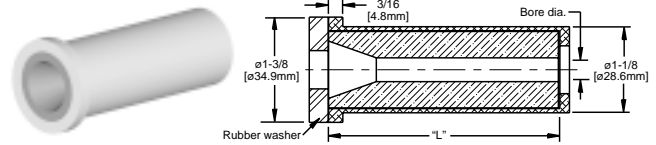

Boron carbide liner with flanged aluminum jacket.

Straight Bore	B Series		
Part Number	Model Number	Bore Diameter	Length
1501033	B3M3-B	3/16" (4.8mm)	3" (76.2mm)
1501043	B4M3-B	1/4" (6.4mm)	3" (76.2mm)
1501053	B5M3-B	5/16" (7.9mm)	3-9/64" (79.8mm)
1501063	B6M3-B	3/8" (9.5mm)	3" (76.2mm)
1501083	B8M3-B	1/2" (12.7mm)	3-9/64" (79.8mm)

**E Series (3-1/8" length) boron carbide straight bore nozzles.**

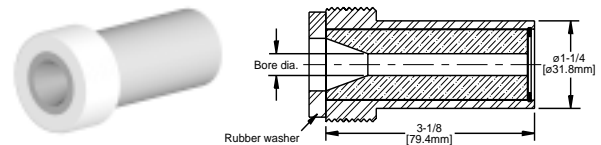

Boron carbide liner with steel jacket and threads.

Straight Bore	E Series		
Thread Style	1-1/4 - 11-1/2 N.P.S.M.		
Part Number	Model Number	Bore Diameter	Length
1503023	B2M3-E	1/8" (3.4mm)	3-1/8" (79.4mm)
1503033	B3M3-E	3/16" (4.8mm)	3-1/8" (79.4mm)
1503043	B4M3-E	1/4" (6.4mm)	3-1/8" (79.4mm)
1503053	B5M3-E	5/16" (7.9mm)	3-1/8" (79.4mm)
1503063	B6M3-E	3/8" (9.5mm)	3-1/8" (79.4mm)
1503083	B8M3-E	1/2" (12.7mm)	3-1/8" (79.4mm)



**E Series (4-1/8" length) straight bore nozzles.**

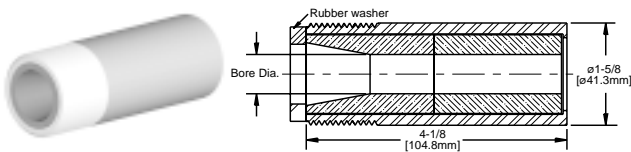

Boron carbide with steel jacket and threads.

Straight Bore	E Series		
Thread Style	1-1/4 – 11-1/2 N.P.S.M.		
Part Number	Model Number	Bore Diameter	Length
1503104	B10M4-E	5/8" (15.9mm)	4-1/8" (104.8mm)

**J Series boron carbide straight bore nozzles.**

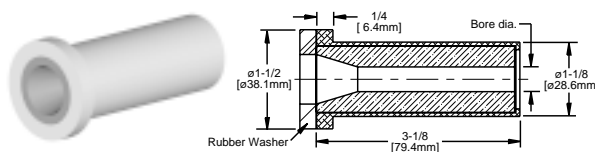

Boron carbide liner with flanged aluminum jacket.

Straight Bore	J Series		
Part Number	Model Number	Bore Diameter	Length
1507033	B3M3-J	3/16" (4.8mm)	3-1/8" (79.4mm)
1507043	B4M3-J	1/4" (6.4mm)	3-1/8" (79.4mm)
1507053	B5M3-J	5/16" (7.9mm)	3-1/8" (79.4mm)
1507063	B6M3-J	3/8" (9.5mm)	3-1/8" (79.4mm)
1507083	B8M3-J	1/2" (12.7mm)	3-1/8" (79.4mm)

**H Series boron carbide straight bore nozzles.**

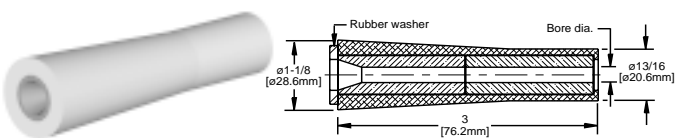

Boron carbide liner with aluminum jacket. 1-1/8" O.D. tapered to 13/16" O.D.

Straight Bore	H Series		
Part Number	Model Number	Bore Diameter	Length
1506023	B2M3-H	1/8" (3.4mm)	3" (76.2mm)
15060231	B2-1/2M3-H	5/32" (4mm)	3" (76.2mm)
1506033	B3M3-H	3/16" (4.8mm)	3" (76.2mm)
1506043	B4M4-H	1/4" (6.4mm)	3" (76.2mm)

**SB Series boron carbide straight bore nozzles.**

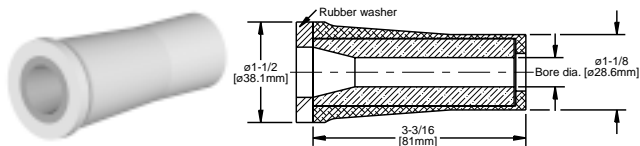

Boron carbide liner with flange tapered aluminum jacket. 1-1/2" O.D. tapered to 1-1/8" O.D.

Flange Assembly	SB Series		
Part Number	Model Number	Bore Diameter	Length
1415060	SB-6	3/8" (9.5mm)	3-3/16" (81mm)
1415070	SB-7	7/16" (11.1mm)	3-3/16" (81mm)
1415080	SB-8	1/2" (12.7mm)	3-3/16" (81mm)

**I Series boron carbide straight bore mid-flange nozzles.**

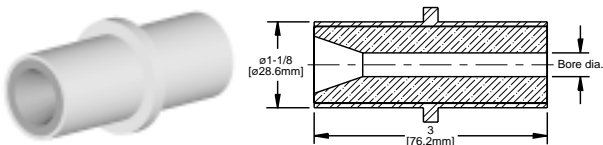

Boron carbide liner with steel jacket and 1-1/2" middle flange.

Straight Bore	I Series		
Part Number	Model Number	Bore Diameter	Length
1511023	B2M3-I	1/8" (3.4mm)	3" (76.2mm)
1511033	B3M3-I	3/16" (4.8mm)	3" (76.2mm)
1511043	B4M3-I	1/4" (6.4mm)	3" (76.2mm)
1511053	B5M3-I	5/16" (7.9mm)	3" (76.2mm)
1511063	B6M3-I	3/8" (9.5mm)	3" (76.2mm)
1511073	B7M3-I	7/16" (11.1mm)	3" (76.2mm)
1511083	B8M3-I	1/2" (12.7mm)	3" (76.2mm)

## SHORT STRAIGHT BORE NOZZLES

These nozzles are used for close-in spot blasting at a range of 12" or less.  
Short straight bore nozzles yield a narrow pattern with little overblast.

### ALUMINUM OXIDE (CERAMIC) SHORT STRAIGHT BORE NOZZLES

Boride Products supplies a full line of premium grade aluminum oxide ceramic nozzles for immediate delivery. If your equipment calls for a non-standard nozzle design, we can produce it for you. For special needs, contact us.

#### CL166 Series aluminum oxide ceramic inserts.

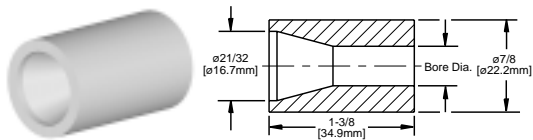

7/8" O.D.

Straight Bore	CL166 Series		
Part Number	Model Number	Bore Diameter	Length
1216640	CL166-4	1/4" (6.4mm)	1-3/8" (34.9mm)
1216650	CL166-5	5/16" (7.9mm)	1-3/8" (34.9mm)
1216660	CL166-6	3/8" (9.5mm)	1-3/8" (34.9mm)
1216670	CL166-7	7/16" (12.7mm)	1-3/8" (34.9mm)

#### CL197 Series aluminum oxide ceramic inserts.

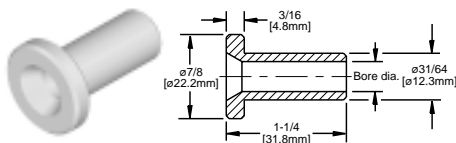

7/8" O.D. flange.

Straight Bore	CL197 Series		
Part Number	Model Number	Bore Diameter	Length
1219740	CL197-4	1/4" (6.4mm)	1-1/4" (31.8mm)
1219750	CL197-5	5/16" (7.9mm)	1-1/4" (31.8mm)

#### CL198 Series aluminum oxide ceramic inserts.

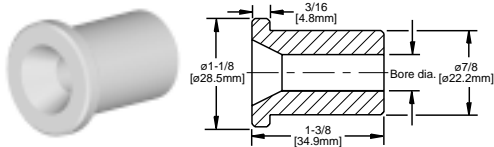

1-1/8" O.D. flange.

Straight Bore	CL198 Series		
Part Number	Model Number	Bore Diameter	Length
1219830	CL198-3	3/16" (4.8mm)	1-3/8" (34.9mm)
1219840	CL198-4	1/4" (6.4mm)	1-3/8" (34.9mm)
1219850	CL198-5	5/16" (7.9mm)	1-3/8" (34.9mm)
1219860	CL198-6	3/8" (9.5mm)	1-3/8" (34.9mm)
1219870	CL198-7	7/16" (11.1mm)	1-3/8" (34.9mm)
1219880	CL198-8	1/2" (12.7mm)	1-3/8" (34.9mm)

#### C2 Series aluminum oxide ceramic inserts.

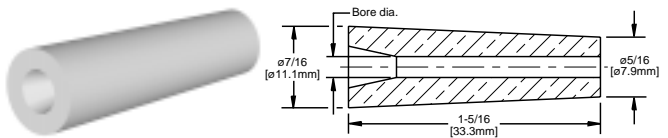

7/16" O.D. tapered to 5/16".

Straight Bore	C2 Series		
Part Number	Model Number	Bore Diameter	Length
1214010	C2-1	3/32" (2.4mm)	1-5/16" (33.3mm)
1214015	C2-1-1/2	7/64" (2.8mm)	1-5/16" (33.3mm)
1214020	C2-2	1/8" (3.2mm)	1-5/16" (33.3mm)
1214025	C2-2-1/2	5/32" (4mm)	1-5/16" (33.3mm)

**C3 Series aluminum oxide sandblasting nozzles.**

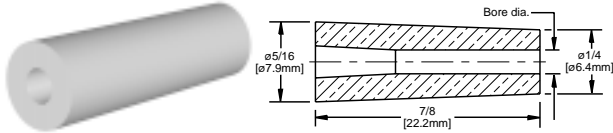

5/16" O.D. tapered to 1/4" O.D. straight bore.

Straight Bore	C3		
Part Number	Model Number	Bore Diameter	Length
1214515	C3-1-1/2	3/32" (2.4mm)	7/8" (22.2mm)

**C3L Series aluminum oxide sandblasting nozzles.**

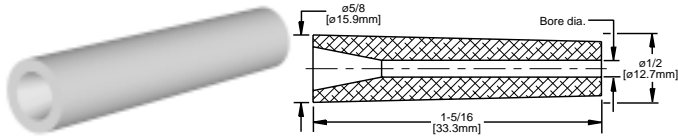

5/8" O.D. tapered to 1/2" O.D. straight bore.

Straight Bore	C3L Series		
Part Number	Model Number	Bore Diameter	Length
1215510	C3L-1-1/4	5/64" (2mm)	1-5/16" (33.3mm)
1215515	C3L-1-1/2	3/32" (2.4mm)	1-5/16" (33.3mm)

**T016 tungsten carbide straight bore nozzle.**

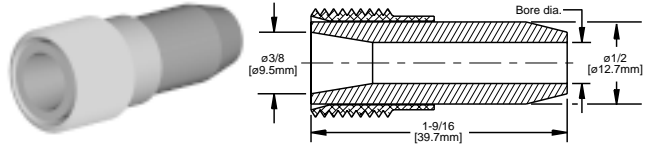

Tungsten carbide with all-brass outer jacket and thread construction.

Straight Nozzles	T016		
Thread Style	3/8 – 18 N.P.S.M.		
Part Number	Model Number	Bore Diameter	Length
1911640	T016-4	1/4" (6.4mm)	1-9/16" (39.7mm)

**TL016-4 tungsten carbide straight bore nozzle insert.**

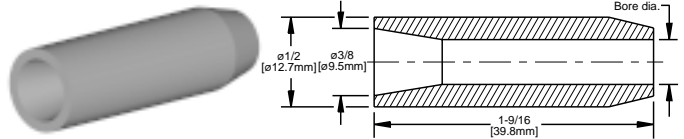

1/2" O.D. insert.

Nozzle Insert	TL016-4		
Part Number	Model Number	Bore Diameter	Length
—	TL016-3	3/16" (4.8mm)	1-9/16" (39.8mm)
1731641	TL016-4	1/4" (6.4mm)	1-9/16" (39.8mm)

**TL100 Series straight bore tungsten carbide air jet inserts.**

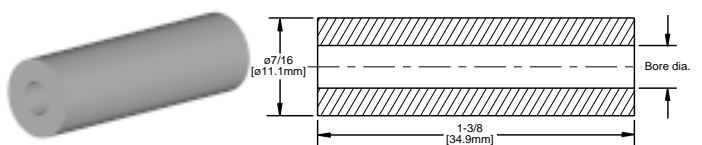

Nozzle Insert	TL100 Series		
Part Number	Model Number	Bore Diameter	Length
1730021	TL100-2	1/8" (3.4mm)	1-3/8" (34.9mm)
1730031	TL100-3	3/16" (4.8mm)	1-3/8" (34.9mm)
1730041	TL100-4	1/4" (6.4mm)	1-3/8" (34.9mm)

**TL104 Series tungsten carbide straight bore nozzle inserts.**

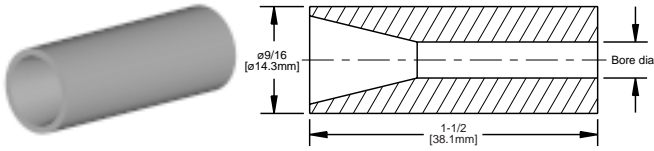

9/16" O.D. insert.

Nozzle Insert		TL104 Series	
Part Number	Model Number	Bore Diameter	Length
1710421	TL104-2	1/8" (3.4mm)	1-1/2" (38.1mm)
1710431	TL104-3	3/16" (4.8mm)	1-1/2" (38.1mm)
1730441	TL104-4	1/4" (6.4mm)	1-1/2" (38.1mm)
1710451	TL104-5	5/16" (7.9mm)	1-1/2" (38.1mm)

**T106 Series tungsten carbide straight bore nozzles.**

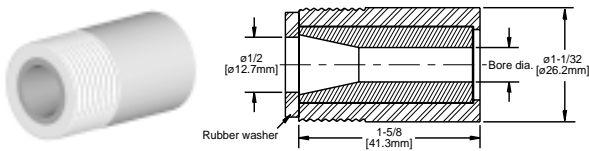

Tungsten carbide liner with steel jacket and threads.

Straight Nozzles		T106 Series	
Thread Style		3/4 - 14 N.P.S.M.	
Part Number	Model Number	Bore Diameter	Length
1910610	T106-1	1/16" (1.6mm)	1-5/8" (41.3mm)
1910615	T106-1-1/2	3/32" (2.4mm)	1-5/8" (41.3mm)
1910620	T106-2	1/8" (3.4mm)	1-5/8" (41.3mm)
1910630	T106-3	3/16" (4.8mm)	1-5/8" (41.3mm)
1910640	T106-4	1/4" (6.4mm)	1-5/8" (41.3mm)
1910650	T106-5	5/16" (7.9mm)	1-5/8" (41.3mm)
1910660	T106-6	3/8" (9.5mm)	1-5/8" (41.3mm)
1910670	T106-7	7/16" (11.1mm)	1-5/8" (41.3mm)
1910680	T106-8	1/2" (12.7mm)	1-5/8" (41.3mm)

**T106-L Series tungsten carbide straight bore nozzles.**

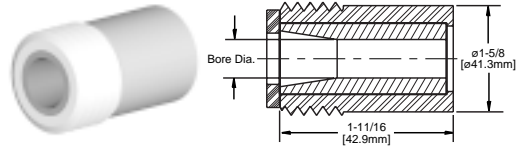

Tungsten carbide nozzle with steel jacket and threads.

Straight Nozzles		T106-L Series	
Thread Style		1-1/8 - 7 AST Class 2 Thd	
Part Number	Model Number	Bore Diameter	Length
1910611	T106-1L	1/16" (1.6mm)	1-11/16" (42.9mm)
1910621	T106-2L	1/8" (3.4mm)	1-11/16" (42.9mm)
1910631	T106-3L	3/16" (4.8mm)	1-11/16" (42.9mm)
1910641	T106-4L	1/4" (6.4mm)	1-11/16" (42.9mm)
1910651	T106-5L	5/16" (7.9mm)	1-11/16" (42.9mm)
1910661	T106-6L	3/8" (9.5mm)	1-11/16" (42.9mm)
1910671	T106-7L	7/16" (11.1mm)	1-11/16" (42.9mm)
1910681	T106-8L	1/2" (12.7mm)	1-11/16" (42.9mm)

**T106-FAP Series tungsten carbide straight bore flanged nozzles.**

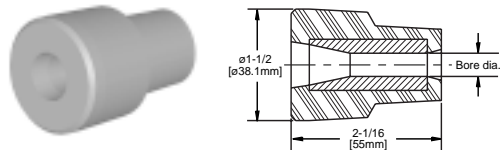

Tungsten carbide nozzle with flanged polyurethane jacket.

Straight Nozzles		T106-FAP Series	
Part Number	Model Number	Bore Diameter	Length
—	T106-3FAP	3/16" (4.8mm)	2-1/16" (55mm)
—	T106-4FAP	1/4" (6.4mm)	2-1/16" (55mm)
—	T106-5FAP	5/16" (7.9mm)	2-1/16" (55mm)

**TL107 Series tungsten carbide air jets.**

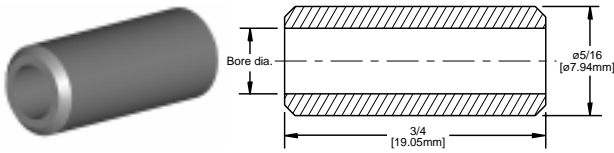

5/16" O.D. insert.

Straight Nozzles		TL107 Series	
Part Number	Model Number	Bore Diameter	Length
1730721	TL107-2	1/8" (3.2mm)	3/4" (19.05mm)
1730725	TL107-2-1/2	5/32" (3.95mm)	3/4" (19.05mm)
1730731	TL107-3	3/16" (4.8mm)	3/4" (19.05mm)
1730741	TL107-4	1/4" (6.4mm)	3/4" (19.05mm)

**T130 Series tungsten carbide air jet assembly.**

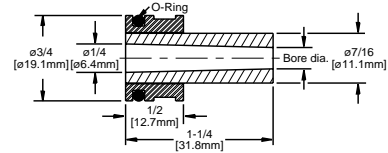

Tungsten carbide liner with steel jacket, grooved, with rubber O-ring. 3/4" O.D., tapered I.D.

Air Jet Nozzles		T130 Series	
Part Number	Model Number	Bore Diameter	Length
1913020	T130-2	1/8" (3.2mm)	1-1/4" (31.8mm)
1913030	T130-3	3/16" (4.8mm)	1-1/4" (31.8mm)
1913040	T130-4	1/4" (6.4mm)	1-1/4" (31.8mm)

**T109 Series tungsten carbide straight bore nozzles.**

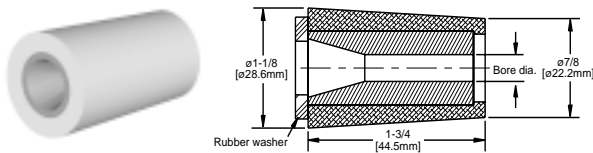

Tungsten carbide liner with aluminum jacket. 1-1/8" O.D. tapered to 7/8" O.D.

Straight Nozzles		T109 Series	
Part Number	Model Number	Bore Diameter	Length
1910910	T109-1	1/16" (1.6mm)	1-3/4" (44.5mm)
1910915	T109-1-1/2	3/32" (2.4mm)	1-3/4" (44.5mm)
1910920	T109-2	1/8" (3.2mm)	1-3/4" (44.5mm)
1910930	T109-3	3/16" (4.8mm)	1-3/4" (44.5mm)
1910940	T109-4	1/4" (6.4mm)	1-3/4" (44.5mm)
1910950	T109-5	5/16" (7.9mm)	1-3/4" (44.5mm)
1910960	T109-6	3/8" (9.5mm)	1-3/4" (44.5mm)

**T133 Series tungsten carbide straight bore nozzles.**

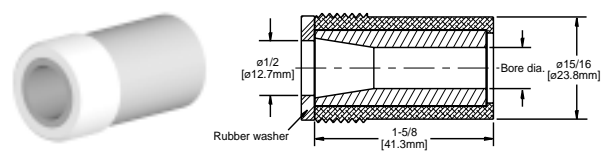

Tungsten carbide liner with aluminum jacket and threads.

Straight Nozzles		T133 Series	
Thread Style	1 - 14 U.N.C.		
Part Number	Model Number	Bore Diameter	Length
1913330	T133-3	3/16" (4.8mm)	1-5/8" (41.3mm)
1913340	T133-4	1/4" (6.4mm)	1-5/8" (41.3mm)
1913350	T133-5	5/16" (7.9mm)	1-5/8" (41.3mm)
1913360	T133-6	3/8" (9.5mm)	1-5/8" (41.3mm)
1913370	T133-7	7/16" (11.1mm)	1-5/8" (41.3mm)
1913380	T133-8	1/2" (12.7mm)	1-5/8" (41.3mm)

**TL117 Series tungsten carbide tapered I.D. air jet inserts.**

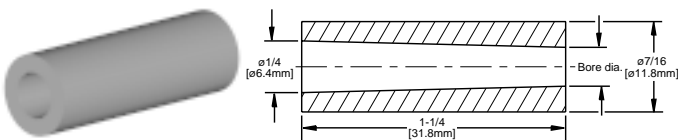

7/16" O.D. insert.

Nozzle Insert		TL117 Series	
Part Number	Model Number	Bore Diameter	Length
1731721	TL-117-2	1/8" (3.4mm)	1-1/4" (31.8mm)
1731731	TL-117-3	3/16" (4.8mm)	1-1/4" (31.8mm)

**T137 Series tungsten carbide straight bore nozzles.**

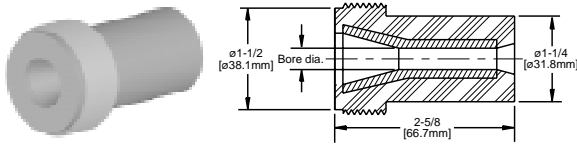

Tungsten carbide with polyurethane jacket and threads.

Straight Nozzles		T137 Series	
Thread Style	1-1/4 – 11-1/2 N.P.S.M.		
Part Number	Model Number	Bore Diameter	Length
2013730	T137-3AP	3/16" (4.8mm)	2-5/8" (66.7mm)
2013740	T137-4AP	1/4" (6.4mm)	2-5/8" (66.7mm)
2013750	T137-5AP	5/16" (7.9mm)	2-5/8" (66.7mm)
2013760	T137-6AP	3/8" (9.5mm)	2-5/8" (66.7mm)
2013780	T137-8AP	1/2" (12.7mm)	2-5/8" (66.7mm)

**TL172 Series tungsten carbide straight bore wide spray inserts.**

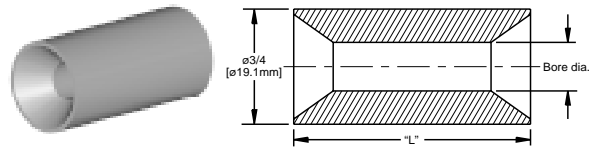

3/4" O.D. insert.

Nozzle Insert		TL172 Series	
Part Number	Model Number	Bore Diameter	Length
1737251	TL172-5	5/16" (7.9mm)	1-1/2" (38.1mm)
1737271	TL172-7	7/16" (11.1mm)	1-7/8" (47.6mm)

**TL166 Series tungsten carbide straight bore inserts.**

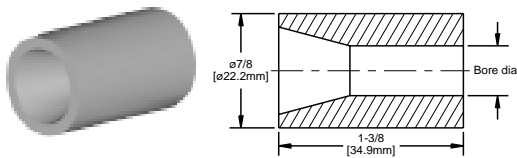

7/8" O.D. insert.

Nozzle Insert		TL166 Series	
Part Number	Model Number	Bore Diameter	Length
1736641	TL166-4	1/4" (6.4mm)	1-3/8" (34.9mm)
1736651	TL166-5	5/16" (7.9mm)	1-3/8" (34.9mm)
1736661	TL166-6	3/8" (9.5mm)	1-3/8" (34.9mm)
1736671	TL166-7	7/16" (11.1mm)	1-3/8" (34.9mm)
1736681	TL166-8	1/2" (12.7mm)	1-3/8" (34.9mm)

**TL175 Series tungsten carbide straight bore inserts.**

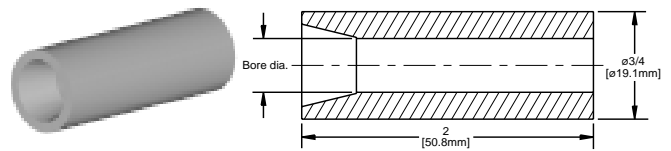

Straight Bore		TL175 Series	
Part Number	Model Number	Bore Diameter	Length
1737541	TL175-4	1/4" (6.4mm)	2" (50.8mm)
1737551	TL175-5	5/16" (7.9mm)	2" (50.8mm)
1737561	TL175-6	3/8" (9.5mm)	2" (50.8mm)
1737581	TL175-8	1/2" (12.7mm)	2" (50.8mm)

**TL171 tungsten carbide straight bore insert.**

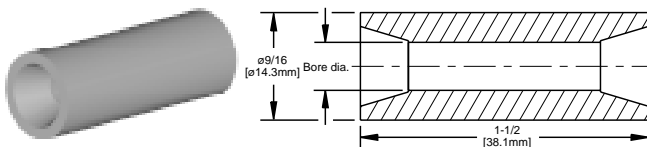

9/16" O.D. insert.

Nozzle Insert		TL171	
Part Number	Model Number	Bore Diameter	Length
1737141	TL171-4	1/4" (6.4mm)	1-1/2" (38.1mm)

**TL197 Series tungsten carbide straight bore flanged inserts.**

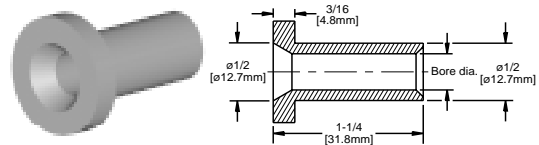

7/8" flange.

Nozzle Insert		TL197 Series	
Part Number	Model Number	Bore Diameter	Length
1719741	TL197-4	1/4" (6.4mm)	1-1/4" (31.8mm)
1719751	TL197-5	5/16" (7.9mm)	1-1/4" (31.8mm)

**T198 Series tungsten carbide straight bore flanged inserts.**

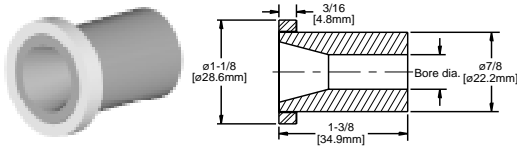

1-1/8" flange.

Gun Insert	T198 Series		
Part Number	Model Number	Bore Diameter	Length
1919840	T198-4	1/4" (6.4mm)	1-3/8" (34.9mm)
1919850	T198-5	5/16" (7.9mm)	1-3/8" (34.9mm)
1919860	T198-6	3/8" (9.5mm)	1-3/8" (34.9mm)
1919870	T198-7	7/16" (11.1mm)	1-3/8" (34.9mm)
1919880	T198-8	1/2" (12.7mm)	1-3/8" (34.9mm)

**TL2 Series tungsten carbide nozzles.**

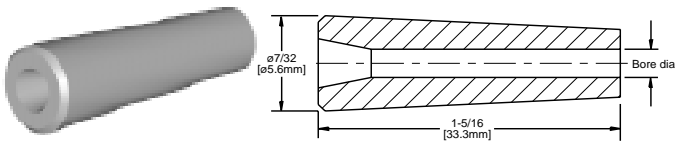

7/32" O.D.

Nozzle Insert	TL2 Series		
Part Number	Model Number	Bore Diameter	Length
1730011	TL2-1	3/32" (2.4mm)	1-5/16" (33.3mm)
1730012	TL2-2	1/8" (3.4mm)	1-5/16" (33.3mm)

**RL2 Series ROCTEC® nozzle.**

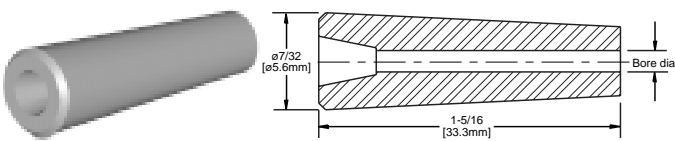

ROCTEC is an extremely durable composite carbide made of tungsten carbide reaction-bonded with molybdenum carbide. This nozzle is solid ROCTEC.

Nozzle Insert	RL2 Series		
Part Number	Model Number	Bore Diameter	Length
—	RL2-1	3/32" (2.4mm)	1-5/16" (33.3mm)

**BORON CARBIDE SHORT LENGTH STRAIGHT BORE NOZZLES**

**B Series (2" length) boron carbide straight bore nozzles.**

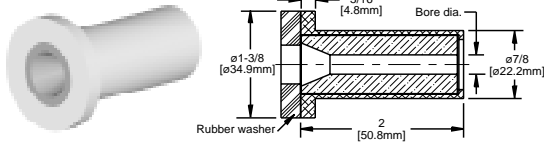

Boron carbide liner with flanged aluminum jacket.

Straight Bore		B Series	
Part Number	Model Number	Bore Diameter	Length
1501022	B2S2-B	1/8" (3.4mm)	2" (50.8mm)
1501032	B3S2-B	3/16" (4.8mm)	2" (50.8mm)
1501042	B4S2-B	1/4" (6.4mm)	2" (50.8mm)
1501052	B5S2-B	5/16" (7.9mm)	2" (50.8mm)
1501062	B6S2-B	3/8" (9.5mm)	2" (50.8mm)

**E Series (2-1/8" length) boron carbide straight bore nozzles.**

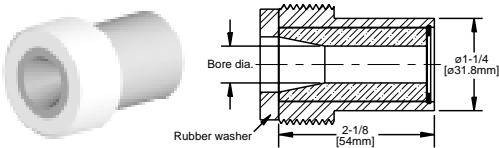

Boron carbide liner with steel jacket and threads.

Straight Bore		E Series	
Thread Style	1-1/4 – 11-1/2 N.P.S.M.		
Part Number	Model Number	Bore Diameter	Length
1503022	B2S2-E	1/8" (3.4mm)	2-1/8" (54mm)
1503032	B3S2-E	3/16" (4.8mm)	2-1/8" (54mm)
1503042	B4S2-E	1/4" (6.4mm)	2-1/8" (54mm)
1503052	B5S2-E	5/16" (7.9mm)	2-1/8" (54mm)
1503062	B6S2-E	3/8" (9.5mm)	2-1/8" (54mm)
1503082	B8S2-E	1/2" (12.7mm)	2-1/8" (54mm)

**G Series boron carbide straight bore nozzles.**

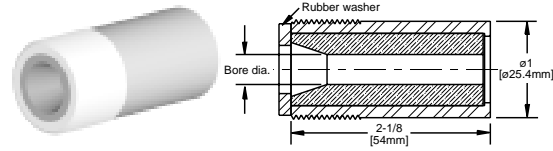

Boron carbide liner with steel jacket and threads.

Straight Bore		G Series	
Thread Style	3/4 – 14 N.P.S.M.		
Part Number	Model Number	Bore Diameter	Length
1505022	B2S2-G	1/8" (3.4mm)	2-1/8" (54mm)
1505032	B3S2-G	3/16" (4.8mm)	2-1/8" (54mm)
1505042	B4S2-G	1/4" (6.4mm)	2-1/8" (54mm)
1505052	B5S2-G	5/16" (7.9mm)	2-1/8" (54mm)
1505062	B6S2-G	3/8" (9.5mm)	2-1/8" (54mm)
1505082	B8S2-G	1/2" (12.7mm)	2-1/8" (54mm)

**GL Series boron carbide straight bore nozzles.**

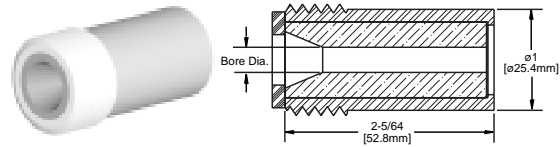

Boron carbide liner with steel jacket and threads.

Straight Bore		GL Series	
Thread Style	1-1/8 – 7 AST Class 2 Thd		
Part Number	Model Number	Bore Diameter	Length
1505023	B2S2-GL	1/8" (3.4mm)	2-5/64" (52.8mm)
1505033	B3S2-GL	3/16" (4.8mm)	2-5/64" (52.8mm)
1505043	B4S2-GL	1/4" (6.4mm)	2-5/64" (52.8mm)
1505053	B5S2-GL	5/16" (7.9mm)	2-5/64" (52.8mm)
1505063	B6S2-GL	3/8" (9.5mm)	2-5/64" (52.8mm)



**H Series boron carbide straight bore nozzles.**

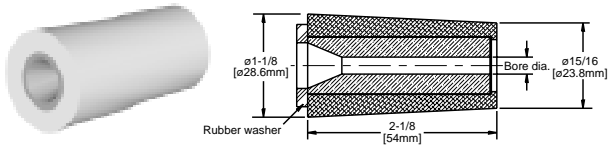

Boron carbide liner with aluminum jacket. 1-1/8" O.D. tapered to 15/16" O.D.

Straight Bore		H Series	
Part Number	Model Number	Bore Diameter	Length
1506022	B2S2-H	1/8" (3.4mm)	2-1/8" (54mm)
15060221	B2-1/2S2-H	5/32" (4mm)	2-1/8" (54mm)
1506032	B3S2-H	3/16" (4.8mm)	2-1/8" (54mm)
1506042	B4S2-H	1/4" (6.4mm)	2-1/8" (54mm)
1506050	B5S2-H	5/16" (7.9mm)	2-1/8" (54mm)

**62 Series boron carbide straight bore inserts.**

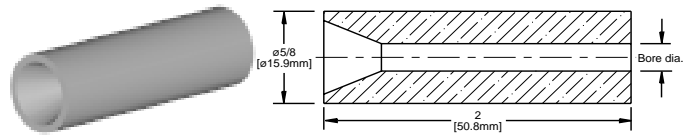

5/8" O.D. insert.

Gun Insert	62 Series		
Part Number	Model Number	Bore Diameter	Length
1162820	B2L-62	1/8" (3.4mm)	2" (50.8mm)
1162825	B2-1/2L-62	5/32" (4mm)	2" (50.8mm)
1162830	B3L-62	3/16" (4.8mm)	2" (50.8mm)
1162840	B4L-62	1/4" (6.4mm)	2" (50.8mm)
1162850	B5L-62	5/16" (7.9mm)	2" (50.8mm)
1162450	B5M-62	5/16" (7.9mm)	1-1/2" (38.1mm)

**75 Series boron carbide straight bore inserts.**

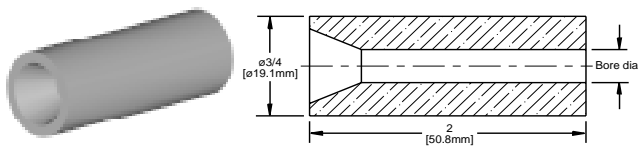

3/4" O.D. insert.

Gun Insert	75 Series		
Part Number	Model Number	Bore Diameter	Length
1175820	B2L-75	1/8" (3.4mm)	2" (50.8mm)
1175830	B3L-75	3/16" (4.8mm)	2" (50.8mm)
1175835	B3-1/2L-75	7/32" (5.6mm)	2" (50.8mm)
1175840	B4L-75	1/4" (6.4mm)	2" (50.8mm)
1175850	B5L-75	5/16" (7.9mm)	2" (50.8mm)
1175860	B6L-75	3/8" (9.5mm)	2" (50.8mm)

**S221 Series boron carbide straight bore nozzles.**

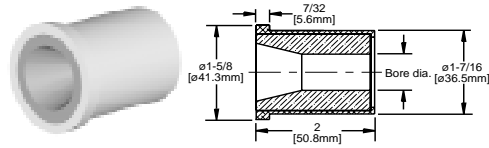

Boron carbide liner with flanged aluminum jacket.

Straight Bore	S221 Series		
Part Number	Model Number	Bore Diameter	Length
1422150	S221-5	5/16" (7.9mm)	2" (50.8mm)
1422160	S221-6	3/8" (9.5mm)	2" (50.8mm)
1422110	S221-10	5/8" (15.9mm)	2" (50.8mm)

**L Series boron carbide straight bore nozzles.**

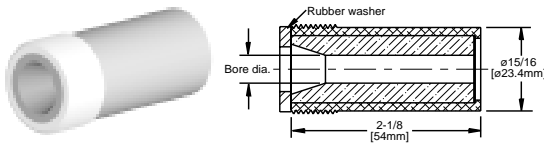

Boron carbide liner with aluminum jacket and threads.

Straight Bore		L Series	
Thread Style	1-1/4 – 11-1/2 N.P.S.M.		
Part Number	Model Number	Bore Diameter	Length
1509022	B2S2-L	1/8" (3.4mm)	2-1/8" (54mm)
1509032	B3S2-L	3/16" (4.8mm)	2-1/8" (54mm)
1509042	B4S2-L	1/4" (6.4mm)	2-1/8" (54mm)
1509052	B5S2-L	5/16" (7.9mm)	2-1/8" (54mm)
1509062	B6S2-L	3/8" (9.5mm)	2-1/8" (54mm)
1509082	B8S2-L	1/2" (12.7mm)	2-1/8" (54mm)

**87 Series boron carbide straight bore inserts.**

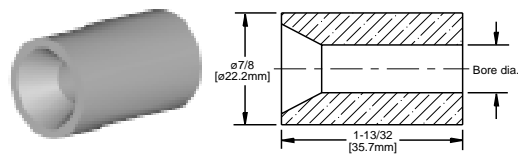

7/8" O.D. insert.

Gun Insert		87 Series	
Part Number	Model Number	Bore Diameter	Length
1187340	B4S-87	1/4" (6.4mm)	1-13/32" (35.7mm)
1187350	B5S-87	5/16" (7.9mm)	1-13/32" (35.7mm)
1187360	B6S-87	3/8" (9.5mm)	1-13/32" (35.7mm)
1187370	B7S-87	7/16" (11.1mm)	1-13/32" (35.7mm)
1187380	B8S-87	1/2" (12.7mm)	1-13/32" (35.7mm)

**60 Series boron carbide straight bore inserts.**

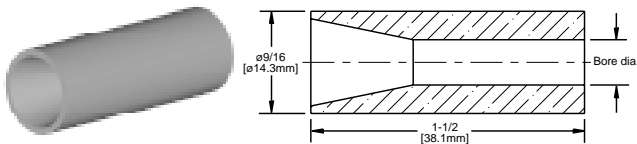

9/16" O.D. insert.

Gun Inserts		60 Series	
Part Number	Model Number	Bore Diameter	Length
1162040	B4S-60	1/4" (6.4mm)	1-1/2" (38.1mm)

**BVI Series boron carbide straight bore—wide spray gun inserts.**

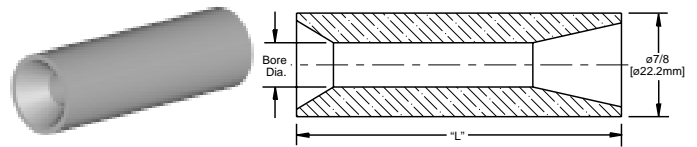

7/8" O.D. insert.

Gun Insert		BVI Series	
Part Number	Model Number	Bore Diameter	Length
1127040	BVI-4	1/4" (6.4mm)	2-13/16" (71.4mm)
1127050	BVI-5	5/16" (7.9mm)	2-13/16" (71.4mm)
1127060	BVI-6	3/8" (9.5mm)	2-3/4" (69.9mm)
1127070	BVI-7	7/16" (11.1mm)	2-13/16" (71.4mm)
1127080	BVI-8	1/2" (12.7mm)	2-13/16" (71.4mm)

**S198 Series boron carbide straight bore nozzles.**

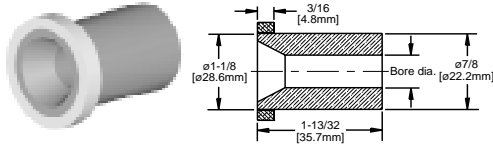

Boron carbide nozzle with steel 1-1/8" O.D. flange.

Gun Insert	S198 Series		
Part Number	Model Number	Bore Diameter	Length
1419840	S198-4	1/4" (6.4mm)	1-13/32" (35.7mm)
1419850	S198-5	5/16" (7.9mm)	1-13/32" (35.7mm)
1419860	S198-6	3/8" (9.5mm)	1-13/32" (35.7mm)
1419870	S198-7	7/16" (11.1mm)	1-13/32" (35.7mm)
1419880	S198-8	1/2" (12.7mm)	1-13/32" (35.7mm)

**S261 Series boron carbide straight bore nozzles.**

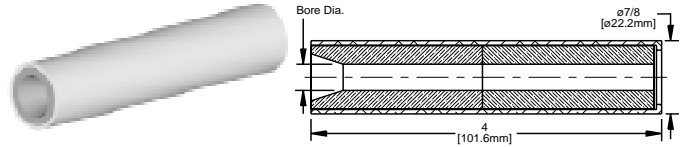

7/8" O.D. insert, boron carbide with aluminum jacket.

Gun Inserts	S261 Series		
Part Number	Model Number	Bore Diameter	Length
1426140	S261-4	1/4" (6.4mm)	4" (101.6mm)
1426150	S261-5	5/16" (7.9mm)	4" (101.6mm)
1426160	S261-6	3/8" (9.5mm)	4" (101.6mm)

**S238 boron carbide straight bore nozzle.**

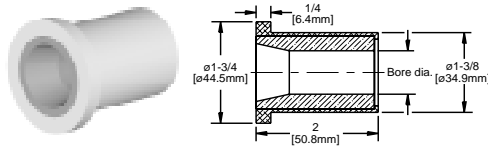

Boron carbide liner with flanged aluminum jacket.

Straight Bore	S238		
Part Number	Model Number	Bore Diameter	Length
1423812	S238-12	3/4" (19.1mm)	2" (50.8mm)

**J Series (2-1/8" length) boron carbide straight bore nozzles.**

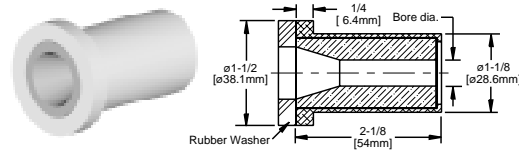

Boron carbide liner with aluminum jacket and 1-1/2" flange.

Straight Bore	J Series		
Part Number	Model Number	Bore Diameter	Length
1507022	B2S2-J	1/8" (3.4mm)	2-1/8" (54mm)
1507042	B4S2-J	1/4" (6.4mm)	2-1/8" (54mm)
1507062	B6S2-J	3/8" (9.5mm)	2-1/8" (54mm)
1507082	B8S2-J	1/2" (12.7mm)	2-1/8" (54mm)

**S258 vacuum blast retainer.**

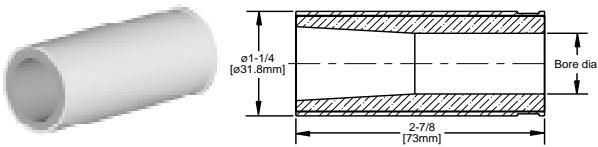

Boron carbide liner with steel jacket with groove.

Straight Bore	S258		
Part Number	Model Number	Bore Diameter	Length
1425812	S258-12	23/32" (18.3mm)	2-7/8" (73mm)

# ANGLE NOZZLES



These nozzles are excellent for getting inside tight places like bridge lattice, behind flanges or inside pipe. Many operators waste abrasive and time waiting for ricochet to get the job done. No nozzle tool chest should be without an angle nozzle. These nozzles are tungsten carbide lined, with brass or aluminum threads, featuring blast outputs at 45° and 90° relative to the input openings. Available with single, double, or triple outlets.

**Special designs available upon request.**

## TUNGSTEN CARBIDE ANGLE NOZZLES

### T045 Single Outlet Series tungsten carbide 45° angle nozzles.

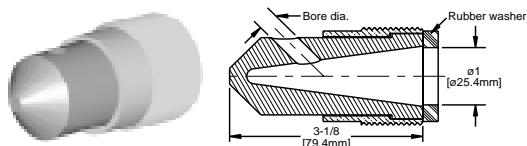

Tungsten carbide nozzle with brass threads.

45° Angle Nozzles	T045 Series		
Thread Style	1-1/4 – 11-1/2 N.P.S.M.		
Part Number	Model Number	Bore Diameter	Length
1904530	T045-3	3/16" (4.8mm)	3-1/8" (79.4mm)
1904540	T045-4	1/4" (6.4mm)	3-1/8" (79.4mm)
1904550	T045-5	5/16" (7.9mm)	3-1/8" (79.4mm)
1904560	T045-6	3/8" (9.5mm)	3-1/8" (79.4mm)
1904580	T045-8	1/2" (12.7mm)	3-1/8" (79.4mm)

### T045 Triple Outlet Series tungsten carbide 45° angle nozzles.

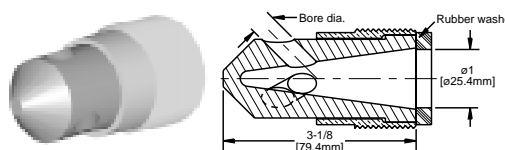

Tungsten carbide nozzle with brass threads.

45° Angles Nozzles	T045 Series		
Thread Style	1-1/4 – 11-1/2 N.P.S.M.		
Part Number	Model Number	Bore Diameter	Length
1904533	T045-33	3/16" (4.8mm)	3-1/8" (79.4mm)
1904543	T045-43	1/4" (6.4mm)	3-1/8" (79.4mm)
1904553	T045-53	5/16" (7.9mm)	3-1/8" (79.4mm)
1904563	T045-63	3/8" (9.5mm)	3-1/8" (79.4mm)
1904583	T045-83	1/2" (12.7mm)	3-1/8" (79.4mm)

### T045 Double Outlet Series tungsten carbide 45° angle nozzles.

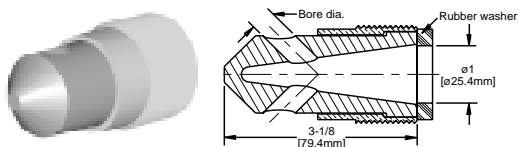

Tungsten carbide nozzle with brass threads.

45° Angle Nozzles	T045 Series		
Thread Style	1-1/4 – 11-1/2 N.P.S.M.		
Part Number	Model Number	Bore Diameter	Length
1904532	T045-32	3/16" (4.8mm)	3-1/8" (79.4mm)
1904542	T045-42	1/4" (6.4mm)	3-1/8" (79.4mm)
1904552	T045-52	5/16" (7.9mm)	3-1/8" (79.4mm)
1904562	T045-62	3/8" (9.5mm)	3-1/8" (79.4mm)
—	T045-82	1/2" (12.7mm)	3-1/8" (79.4mm)

### T045-50mm Single Outlet Series tungsten carbide 45° angle nozzles.

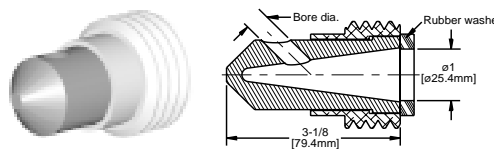

Tungsten carbide nozzle with aluminum threads.

45° Angle Nozzles	T045-50mm Series		
Thread Style	2 – 4-1/2 U.N.C.		
Part Number	Model Number	Bore Diameter	Length
1904534	T045-350	3/16" (4.8mm)	3-1/8" (79.4mm)
1904544	T045-450	1/4" (6.4mm)	3-1/8" (79.4mm)
1904554	T045-550	5/16" (7.9mm)	3-1/8" (79.4mm)
1904564	T045-650	3/8" (9.5mm)	3-1/8" (79.4mm)
1904584	T045-850	1/2" (12.7mm)	3-1/8" (79.4mm)

**T045-50mm Double Outlet Series tungsten carbide 45° angle nozzles.**

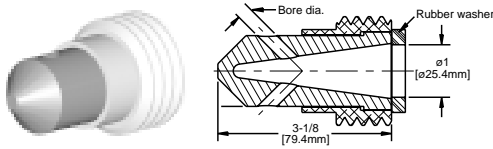

Tungsten carbide nozzle with aluminum threads.

45° Angle Nozzle	T045-50mm Series		
Thread Style	2 – 4-1/2 U.N.C.		
Part Number	Model Number	Bore Diameter	Length
1904535	T045-32-50mm	3/16" (4.8mm)	3-1/8" (79.4mm)
1904545	T045-42-50mm	1/4" (6.4mm)	3-1/8" (79.4mm)
1904555	T045-52-50mm	5/16" (7.9mm)	3-1/8" (79.4mm)
1904565	T045-62-50mm	3/8" (9.5mm)	3-1/8" (79.4mm)
—	T045-82-50mm	1/2" (12.7mm)	3-1/8" (79.4mm)

**T045-Reverse Multiple Outlet Series tungsten carbide 125° angle nozzles.**

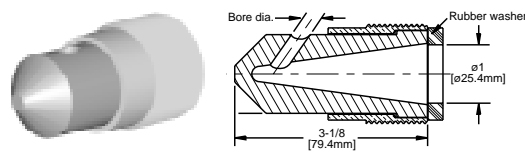

Tungsten carbide nozzle with brass threads. Single, double or triple outlets.

125° Angle Nozzle	T045 Series		
Thread Style	1-1/4 – 11-1/2 N.P.S.M.		
Part Number	Model Number	Bore Diameter	Length
1904530R	T045-3R	3/16" (4.8mm) sgl.	3-1/8" (79.4mm)
1904540R	T045-4R	1/4" (6.4mm) sgl.	3-1/8" (79.4mm)
1904543R	T045-43R	1/4" (6.4mm) trpl.	3-1/8" (79.4mm)
1904553R	T045-53R	5/16" (7.9mm) trpl.	3-1/8" (79.4mm)
1904560R	T045-6R	3/8" (9.5mm) sgl.	3-1/8" (79.4mm)
—	T045-8R	1/2" (12.7mm) sgl.	3-1/8" (79.4mm)

**T045-50mm Triple Outlet Series tungsten carbide 45° angle nozzles.**

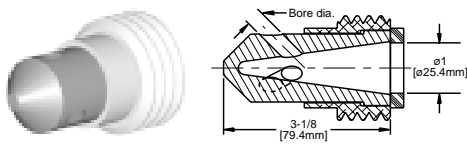

Tungsten carbide nozzle with aluminum threads.

45° Angle Nozzle	T045-50mm Series		
Thread Style	2 – 4-1/2 U.N.C.		
Part Number	Model Number	Bore Diameter	Length
1904536	T045-33-50mm	3/16" (4.8mm)	3-1/8" (79.4mm)
1904546	T045-43-50mm	1/4" (6.4mm)	3-1/8" (79.4mm)
1904556	T045-53-50mm	5/16" (7.9mm)	3-1/8" (79.4mm)
1904566	T045-63-50mm	3/8" (9.5mm)	3-1/8" (79.4mm)

**T090 Single Outlet Series tungsten carbide 90° angle nozzles.**

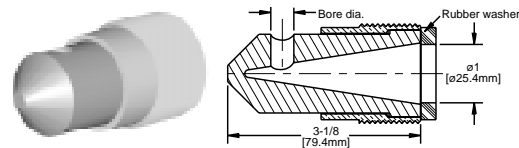

Tungsten carbide nozzle with brass threads.

90° Angle Nozzles	T090 Series		
Thread Style	1-1/4 – 11-1/2 N.P.S.M.		
Part Number	Model Number	Bore Diameter	Length
1909030	T090-3	3/16" (4.8mm)	3-1/8" (79.4mm)
1909040	T090-4	1/4" (6.4mm)	3-1/8" (79.4mm)
1909050	T090-5	5/16" (7.9mm)	3-1/8" (79.4mm)
1909060	T090-6	3/8" (9.5mm)	3-1/8" (79.4mm)
1909080	T090-8	1/2" (12.7mm)	3-1/8" (79.4mm)

**T090 Double Outlet Series tungsten carbide 90° angle nozzles.**

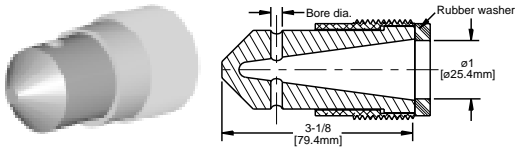

Tungsten carbide nozzle with brass threads.

90° Angle Nozzles		T090 Series	
Thread Style		1-1/4 – 11-1/2 N.P.S.M.	
Part Number	Model Number	Bore Diameter	Length
1909032	T090-32	3/16" (4.8mm)	3-1/8" (79.4mm)
1909042	T090-42	1/4" (6.4mm)	3-1/8" (79.4mm)
1909052	T090-52	5/16" (7.9mm)	3-1/8" (79.4mm)
1909062	T090-62	3/8" (9.5mm)	3-1/8" (79.4mm)
—	T090-82	1/2" (12.7mm)	3-1/8" (79.4mm)

**T090-50mm Single Outlet Series tungsten carbide 90° angle nozzles.**

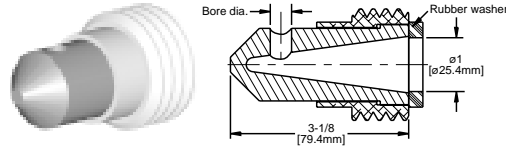

Tungsten carbide nozzle with aluminum threads.

90° Angle Nozzles		T090-50mm Series	
Thread Style		2 – 4-1/2 U.N.C.	
Part Number	Model Number	Bore Diameter	Length
—	T090-350	3/16" (4.8mm)	3-1/8" (79.4mm)
—	T090-450	1/4" (6.4mm)	3-1/8" (79.4mm)
—	T090-550	5/16" (7.9mm)	3-1/8" (79.4mm)
1909064	T090-650	3/8" (9.5mm)	3-1/8" (79.4mm)
1909084	T090-850	1/2" (12.7mm)	3-1/8" (79.4mm)

**T090 Triple Outlet Series tungsten carbide 90° angle nozzles.**

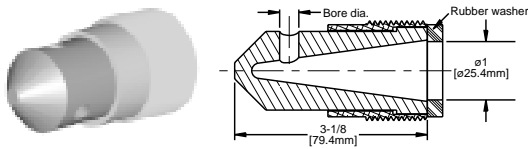

Tungsten carbide nozzle with brass threads.

90° Angles Nozzles		T090 Series	
Thread Style		1-1/4 – 11-1/2 N.P.S.M.	
Part Number	Model Number	Bore Diameter	Length
1909033	T090-33	3/16" (4.8mm)	3-1/8" (79.4mm)
1909043	T090-43	1/4" (6.4mm)	3-1/8" (79.4mm)
1909053	T090-53	5/16" (7.9mm)	3-1/8" (79.4mm)
1909063	T090-63	3/8" (9.5mm)	3-1/8" (79.4mm)

**T145 Multiple Outlet Series tungsten carbide 60° angle nozzles.**

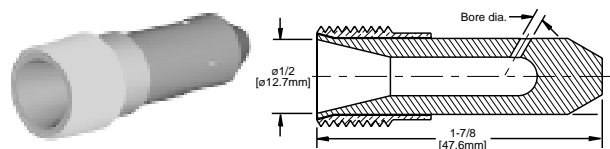

Tungsten carbide nozzle with brass threads. Single, triple, or quad outlets.

60° Angle Nozzles		T145 Series	
Thread Style		3/8 – 18 N.P.S.M.	
Part Number	Model Number	Bore Diameter	Length
1914520	T145-2	1/8" (3.2mm) sgl.	1-7/8" (47.6mm)
1914522	T145-22	1/8" (3.2mm) dbl.	1-7/8" (47.6mm)
1914523	T145-23	1/8" (3.2mm) trpl.	1-7/8" (47.6mm)
1914524	T145-24	1/8" (3.2mm) quad.	1-7/8" (47.6mm)
1914530	T145-3	3/16" (4.8mm) sgl.	1-7/8" (47.6mm)
1914540	T145-4	1/4" (6.4mm) sgl.	1-7/8" (47.6mm)
1914542	T145-42	1/4" (6.4mm) dbl.	1-7/8" (47.6mm)

**T190 Multiple Outlet Series tungsten carbide 90° angle nozzles.**

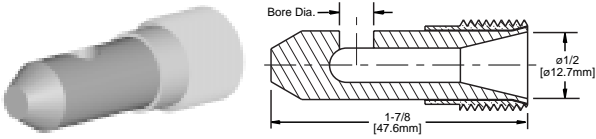

Tungsten carbide nozzle with brass threads. Single, triple, or quad outlets.

90° Angles Nozzles	T190 Series		
Thread Style	3/8 – 18 N.P.S.M.		
Part Number	Model Number	Bore Diameter	Length
—	T190-2	1/8" (3.2mm) sgl.	1-7/8" (47.6mm)
—	T190-23	1/8" (3.2mm) trpl.	1-7/8" (47.6mm)
1919024	T190-24	1/8" (3.2mm) quad.	1-7/8" (47.6mm)
1919030	T190-3	3/16" (4.8mm) sgl.	1-7/8" (47.6mm)
1919040	T190-4	1/4" (6.4mm) sgl.	1-7/8" (47.6mm)

**T290 Series tungsten carbide 90° angle nozzles.**

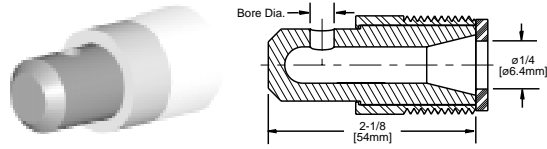

Tungsten carbide nozzle with steel threads. Single, double, or triple outlets.

90° Angle Nozzle	T290 Series		
Thread Style	3/4" – 14" N.P.S.M.		
Part Number	Model Number	Bore Diameter	Length
—	T290-2	1/8" (3.2mm) sgl.	2-1/8" (54mm)
1929022	T290-22	1/8" (3.2mm) dbl.	2-1/8" (54mm)
—	T290-3	3/16" (4.8mm) sgl.	2-1/8" (54mm)
1929033	T290-33	3/16" (4.8mm) trpl.	2-1/8" (54mm)
1929041	T290-4	1/4" (6.4mm) sgl.	2-1/8" (54mm)
—	T290-42	1/4" (6.4mm) dbl.	2-1/8" (54mm)
1929051	T290-5	5/16" (7.9mm) sgl.	2-1/8" (54mm)
1929061	T290-6	3/8" (9.5mm) sgl.	2-1/8" (54mm)

**T245 Multiple Outlet Series tungsten carbide 45° angle nozzles.**

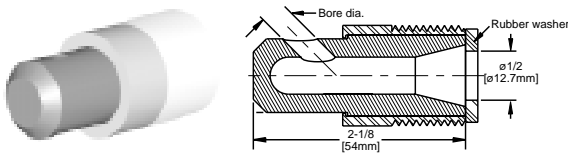

Tungsten carbide nozzle with steel threads. Single, double, or triple outlets.

45° Angle Nozzle	T245 Series		
Thread Style	3/4" – 14" N.P.S.M.		
Part Number	Model Number	Bore Diameter	Length
1924521	T245-2	1/8" (3.2mm) sgl.	2-1/8" (54mm)
1924523	T245-23	1/8" (3.2mm) trpl.	2-1/8" (54mm)
1924531	T245-3	3/16" (4.8mm) sgl.	2-1/8" (54mm)
1924533	T245-33	3/16" (4.8mm) trpl.	2-1/8" (54mm)
1924541	T245-4	1/4" (6.4mm) sgl.	2-1/8" (54mm)
1924542	T245-42	1/4" (6.4mm) dbl.	2-1/8" (54mm)
1924551	T245-5	5/16" (7.9mm) sgl.	2-1/8" (54mm)
1924561	T245-6	3/8" (9.5mm) sgl.	2-1/8" (54mm)

# WET BLAST NOZZLES



## WIN® (WATER INDUCTION NOZZLE) SYSTEM FOR WET ABRASIVE BLASTING

The WIN (Water Induction Nozzle) System is a simple patented solution for high production, wet abrasive blasting that can be used with your existing pressure blast equipment. The system can be used with water from a tap or with rust inhibitors introduced through any simple pump. No special equipment is required.

The WIN System offers the highest performance possible in wet abrasive blasting technology.

There are five sizes of WIN System nozzles available, with either metric or American threads. All of these nozzles use a standard 1" I.D. blast hose and all can be used as a wet or dry blast nozzle. Water consumption with these nozzles is much less than with other wet blast systems, only 3/4 to 6 quarts per minute depending on the level of dust suppression desired. All brass outer construction with tungsten liner.

### WIN System Series double venturi bore nozzles.

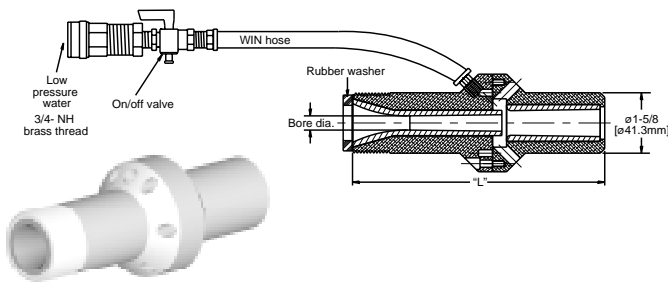

Tungsten carbide liner with aluminum jacket and threads.

### WIN 50mm Series double venturi bore nozzles.

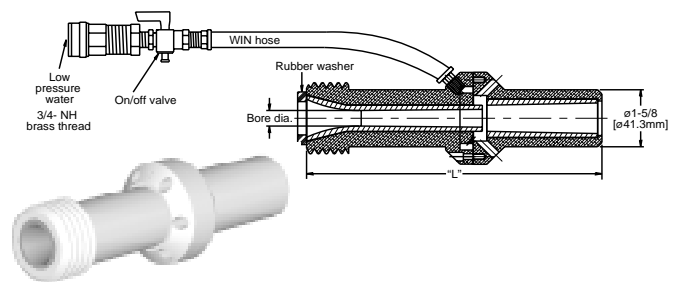

Tungsten carbide liner with aluminum jacket and threads.

Venturi Bore	WIN Series		
Thread Style	1-1/4 – 11-1/2 N.P.S.M.		
Part Number	Model Number	Bore Diameter	Length
1912535	WIN-3	3/16" (4.8mm)	5" (127mm)
1912545	WIN-4	1/4" (6.4mm)	5-3/4" (146.1mm)
1912555	WIN-5	5/16" (7.9mm)	6-1/4" (158.8mm)
1912565	WIN-6	3/8" (9.5mm)	6-3/4" (171.5mm)
1912575	WIN-7	7/16" (11.1mm)	8-1/4" (209.6mm)
1912585	WIN-8	1/2" (12.7mm)	9" (228.6mm)

Venturi Bore	WIN 50mm Series		
Thread Style	2 – 4-1/2 U.N.C.		
Part Number	Model Number	Bore Diameter	Length
1912547	WIN-450	1/4" (6.4mm)	5-3/4" (146.1mm)
1912557	WIN-550	5/16" (7.9mm)	6-1/4" (158.8mm)
1912567	WIN-650	3/8" (9.5mm)	6-3/4" (171.5mm)
1912577	WIN-750	7/16" (11.1mm)	8-1/4" (209.6mm)
1912587	WIN-850	1/2" (12.7mm)	9" (228.6mm)



## SIPHON BLAST SHORT NOZZLES

Use with no larger than a 3/4" I.D. blast hose. Features a relatively short, straight bore. Excellent for wet blasters with siphon pick-up.

### TUNGSTEN CARBIDE SIPHON BLAST SHORT NOZZLES

T137-AP Series tungsten carbide siphon blast short nozzles.

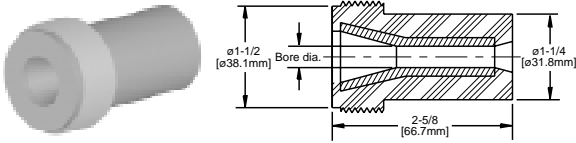

Tungsten carbide liner with polyurethane jacket and threads.

Siphon Blast Nozzles	T137-AP Series		
Thread Style	1-1/4 – 11-1/2 N.P.S.M.		
Part Number	Model Number	Bore Diameter	Length
2013730	T137-3AP	3/16" (4.8mm)	2-1/2" (63.5mm)
2013740	T137-4AP	1/4" (6.4mm)	2-1/2" (63.5mm)
2013750	T137-5AP	5/16" (7.9mm)	2-1/2" (63.5mm)
2013760	T137-6AP	3/8" (9.5mm)	2-1/2" (63.5mm)
2013780	T137-8AP	1/2" (12.7mm)	2-1/2" (63.5mm)

# RS-2000 ABRASIVE BLASTING GUNS AND REPLACEMENT PARTS



Boride Products engineers have created an ergonomically designed abrasive blasting gun to allow operators to complete cleaning jobs faster, more easily and more economically. This lightweight, durable one-piece gun is constructed of high-density polyurethane, with a palm grip and thumb hole to give enhanced control and comfort. At only 14 ounces, this device reduces operator fatigue and gives greater control of high pressure blasting than other systems. Available in right and left hand models.

The RS-2000 Abrasive Blasting Gun is available in a complete assembly that includes gun body, nozzle, matching air jet, cartridge, gun fitting kit and screws. You may also purchase components and replacement parts separately. Air jets and nozzles available in tungsten carbide or boron carbide in a variety of sizes.

## COMPLETE RS-2000 SUCTION BLAST GUN ASSEMBLIES (GUN BODY, NOZZLE, MATCHING AIR JET, CARTRIDGE, GUN FITTING KIT, SCREWS)

RS-2000 Suction Blast Gun		
Model No.	Item	Bore Size
16106BR	Gun assembly	1/4" tungsten carbide nozzle, right hand
16106BL	Gun assembly	1/4" tungsten carbide nozzle, left hand
16103BR	Gun assembly	1/4" boron carbide nozzle, right hand
16103BL	Gun assembly	1/4" boron carbide nozzle, left hand
16105BR	Gun assembly	5/16" tungsten carbide nozzle, right hand
16105BL	Gun assembly	5/16" tungsten carbide nozzle, left hand
16102BR	Gun assembly	5/16" boron carbide nozzle, right hand
16102BL	Gun assembly	5/16" boron carbide nozzle, left hand
16104BR	Gun assembly	3/8" tungsten carbide nozzle, right hand
16104BL	Gun assembly	3/8" tungsten carbide nozzle, left hand
16101BR	Gun assembly	3/8" boron carbide nozzle, right hand
16101BL	Gun assembly	3/8" boron carbide nozzle, left hand
16108BR	Gun assembly	1/2" tungsten carbide nozzle, right hand
16108BL	Gun assembly	1/2" tungsten carbide nozzle, left hand
16107BR	Gun assembly	1/2" boron carbide nozzle, right hand
16107BL	Gun assembly	1/2" boron carbide nozzle, left hand

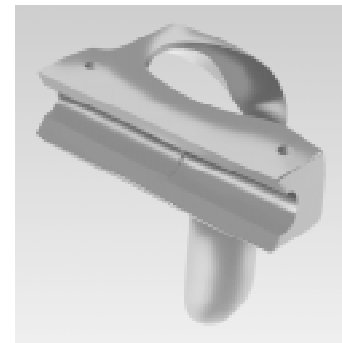

## RS-2000 Pressure Blast Gun (includes two tie straps)

1300301	Gun body, polyurethane, right hand
1300302	Gun body, polyurethane, left hand

## SUCTION BLAST AIR REQUIREMENTS (SCFM)

Pressure (psi)	30	40	50	60	70	80	90	100
1/4" nozzle, 1/8" air jet	10	12	15	17	19	21	23	26
5/16" nozzle, 5/32" air jet	15	19	23	27	31	37	38	42
3/8" nozzle, 3/16" air jet	22	26	30	35	40	45	49	54
1/2" nozzle, 1/4" air jet	36	45	53	60	67	74	81	87

## HOSE KIT

Hose kit for 5/8" I.D. abrasive feed hose includes:

- 10 ft 1/2" I.D. compressed air hose
- 10 ft 5/8" I.D. abrasive feed hose (polyurethane)
- air fitting: 1/2" I.D. hose connection (brass)
- abrasive fitting: 5/8" I.D. hose (steel)
- 2 tie straps
- tie strap with mounting hole
- 2 stainless steel hose clamps.



# REPLACEMENT PARTS, NOZZLES, AND AIR JETS FOR RS-2000 BLAST GUN

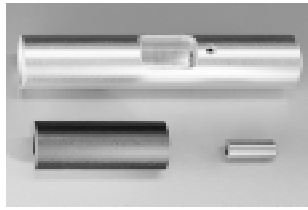

## Replacement Parts For RS-2000

130030	Gun fitting kit: 2 hose clamps, 2 1/2" air fittings, 5/8" abrasive fitting
130017	Aluminum cartridge body 1/4", 5/16", 3/8" nozzles
130028	Aluminum cartridge body, 1/2" bore nozzles
130117	Set screw for air jet assembly
130013	Air fitting, 1/2" I.D. hose connection—brass
130016	Air fitting, JIC hose connection—brass
130005	Hose clamp—stainless steel
130011	Mounting screw for gun body/cartridge
130015	Abrasive fitting, 5/8" I.D. hose connection—steel
130012	Tie strap
130018	Tie strap with mounting hole
1300007	Gun body, polyurethane, right hand
1300008	Gun body, polyurethane, left hand

## TL175 Series tungsten carbide gun inserts.

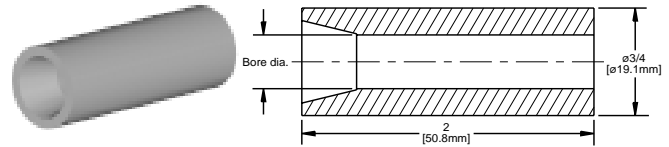

Straight Bore	TL175 Series		
Part Number	Model Number	Bore Diameter	Length
1737541	TL175-4	1/4" (6.4mm)	2" (50.8mm)
1737551	TL175-5	5/16" (7.9mm)	2" (50.8mm)
1737561	TL175-6	3/8" (9.5mm)	2" (50.8mm)
1737581	TL175-8	1/2" (12.7mm)	2" (50.8mm)

## BORON CARBIDE NOZZLES AND AIR JETS FOR RS-2000 GUN

## TUNGSTEN CARBIDE NOZZLES AND AIR JETS FOR RS-2000 GUN

### TL107 Series tungsten carbide air jet inserts.

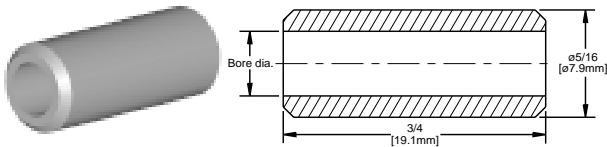

Straight bore, 5/16" O.D.

Air Jet inserts	Air Jet		
Part Number	Model Number	Bore Diameter	Length
1730721	TL107-2	1/8" (3.4mm)	3/4" (19.1mm)
1730725	TL107-2-1/2	5/32" (4mm)	3/4" (19.1mm)
1730731	TL107-3	3/16" (4.8mm)	3/4" (19.1mm)
1730741	TL107-3-1/2	1/4" (6.4mm)	3/4" (19.1mm)

### Boron carbide gun inserts.

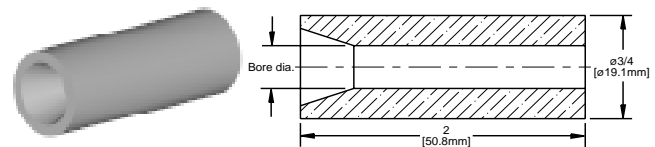

Straight Bore	Gun Insert		
Part Number	Model Number	Bore Diameter	Length
1175840	B4L-75	1/4" (6.4mm)	2" (50.8mm)
1175850	B5L-75	5/16" (7.9mm)	2" (50.8mm)
1175860	B6L-75	3/8" (9.5mm)	2" (50.8mm)
1123080	L230-8	1/2" (12.7mm)	2" (50.8mm)

## ACCESSORIES

### Rubber Washers/Gaskets

Part Number	Size
130110	Small 1" O.D. x 1/2" I.D.
130111	Medium 1-1/2" O.D. x 3/4" I.D.
130112	Large 1-1/2" O.D. x 1" I.D.

### Hose for Water Induction Nozzle (WIN) System

Item	Part Number
WIN Hose	1912500

### 50mm Thread Adapter

Item	Part Number
Adapter: 1-1/4" to 50mm, 2-4-1/2" UNC thread	130784

### Deflector Tips for Hollo Blaster

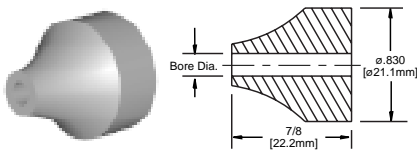

Part Number	Item	Size
BB99115A	Tungsten Carbide Deflector Tip	.830" O.D.
BD98114A	ROCTEC® 500 Deflector Tip	.830" O.D.

## **There's more to the Boride story than what you see in this catalog**

Boride Products is the leading North American manufacturer of blast nozzles and related flow control devices for contractor abrasive blasting in the construction industry, and for suction and pressure blast cabinets in the manufacturing industries. We offer tungsten carbide, silicon carbide composite, boron carbide and aluminum oxide nozzles and inserts in hundreds of sizes and styles.

## **Our selection of nozzles is unmatched, anywhere**

We have standard products that can replace the original nozzles installed on most equipment. We also have higher performance upgrades for most OEM products to allow you to achieve optimum blasting effectiveness, efficiency and reduce your total costs.

## **We make the highest quality products**

Our specialty is understanding material systems from the microstructural level through to the finished part. We engineer the materials to match the finished nozzle design. And our quality standards require us to use only the finest raw materials and most expert workmanship.

## **Boride staff know what they're talking about**

When you call us for help, you get a nozzle expert on the line. Our sales staff has more nozzle knowledge and blasting applications experience than you'll find at many equipment manufacturers. With just a phone call, you get instant access to help with diagnosing and solving blasting problems.

## **You can't beat the convenience of doing business with us**

When a nozzle fails, you need a replacement fast. That's why we ship 95% of all orders within 24 hours—many are shipped out the same day. We'll work with you directly or through your local distributor, whichever is faster and better for you.

## **When you need nozzles, ask for Boride.**

Boride Products  
2879 Aero Park Drive  
Traverse City, MI 49686 USA  
Phone (800) 662-2131 or (231) 946-2100  
Fax (800) 662-2132 or (231) 946-3025  
[www.boride.com](http://www.boride.com)

**Distributed by:**



**Bringing Ceramic  
Technology to Industry**

Boride Products  
2879 Aero Park Drive  
Traverse City, MI 49686 USA

*For additional information on Boride blasting nozzles,*

Call toll free 800-662-2131 (U.S. only) or 231-946-2100  
Or fax toll-free 800-662-2132 (U.S. only) or 231-946-3025.

[www.boride.com](http://www.boride.com)

**A division of the Kennametal Engineered Products Group**



**NOTICE:** No freedom from any patent owned by Seller or others is to be inferred. Because use conditions and applicable laws may differ from one location to another and may change with time, Customer is responsible for determining whether products and the information in this document are appropriate for Customer's use and for ensuring that Customer's workplace and disposal practices are in compliance with applicable laws and other governmental enactments. Seller assumes no obligation or liability for the information in this document. NO WARRANTIES ARE GIVEN; ALL IMPLIED WARRANTIES OF MERCHANTABILITY OR FITNESS FOR A PARTICULAR PURPOSE ARE EXPRESSLY EXCLUDED.